

PEOPLE'S DEMOCRATIC REPUBLIC OF ALGERIA
Ministry of Higher Education and Scientific Research

Larbi Tébessi University of Tébessa



Faculty of Exact, Natural and Life Sciences
Department of Mathematics and Computer Sciences

Formation Domain: Mathematics and Informatic

Analysis 4

Intended
To
Second year Bachelor's student's

Matter: Analysis 4
Specialty: Mathematics

By

Abderrazak Nabti

2023-2024

Contents

1	Introduction to Topology in \mathbb{R}^n	4
1	Vector space	4
2	Open/closed set	7
3	Closure, interior, boundary,	8
2	Function of several variable	9
1	Functions of several variables	9
2	Level curves	11
3	Exercises	12
3	Limit and continuity	20
1	Limit	20
2	Continuity	27
3	Exercises	28
4	Partial derivatives	42
1	Partial derivatives of $f : \mathbb{R}^n \rightarrow \mathbb{R}$	42
2	Higher order derivative	48
3	Chiane rules	51
4	Exercises	54
5	Differentiability	62
1	Differentiability	62
2	The Implicit Function Theorem	67
3	Inverse function Theorem	69
4	Exercises	70
6	Extrema	84
1	Local extrema	84
2	Absolute extrema	89
3	Lagrange multiplier	90
4	Exercises	90
7	Multiple Integrals	94
1	Double integral	94
2	Double integrals over general regions	96
3	Change the order of the integration	97
4	Volumes and area using double integral	98

5	Change of variable in double integral	99
6	Triple integral	103
7	Triple integrals over general bounded solids	104
8	Exercises:	109

This lecture note is intended for second-year Mathematics Bachelor's students. Its aim is to cover the fundamental concepts of differential calculus for multivariable functions. It includes topics such as continuity, partial derivatives, differentiability, the implicit function theorem, and the inverse theorem. Additionally, it offers a comprehensive understanding of double and triple integrals.

Chapter 1

Introduction to Topology in \mathbb{R}^n

1 Vector space

Definition 1.1. A vector space consists of a set \mathbb{E} (elements of \mathbb{E} are called vectors), a field \mathbb{K} (elements of \mathbb{K} are called scalars), and two operations:

- An operation called vector addition that takes two vectors $u, v \in \mathbb{E}$, and produces a third vector, written $u + v \in \mathbb{E}$.
- An operation called scalar multiplication that takes a scalar $\alpha \in \mathbb{K}$ and a vector $u \in \mathbb{E}$, and produces a new vector, written $\alpha u \in \mathbb{E}$.

which satisfy the following conditions (called axioms).

1. Associativity of vector addition: $(u + v) + w = u + (v + w)$ for all $u, v, w \in \mathbb{E}$.
2. Existence of a zero vector: There is a vector in \mathbb{E} , written 0 and called the zero vector, which has the property that $u + 0 = u$ for all $u \in \mathbb{E}$.
3. Existence of negatives: For every $u \in \mathbb{E}$, there is a vector in \mathbb{E} , written $-u$ and called the negative of u , which has the property that $u + (-u) = 0$.
4. Associativity of multiplication: $(\alpha\beta)u = \alpha(\beta u)$ for any $\alpha, \beta \in \mathbb{K}$ and $u \in \mathbb{E}$.
5. Distributivity: $(\alpha + \beta)u = \alpha u + \beta u$ and $\alpha(u + v) = \alpha u + \alpha v$ for all $\alpha, \beta \in \mathbb{K}$ and $u, v \in \mathbb{E}$.
6. Unitality: $1u = u$ for all $u \in \mathbb{E}$.

Example 1.2. The space

$$\begin{aligned}\mathbb{R}^n &= \underbrace{\mathbb{R} \times \mathbb{R} \times \cdots \times \mathbb{R}}_{n \text{ times}} \\ &= \{x = (x_1, x_2, \dots, x_n), \text{ such that } x_i \in \mathbb{R}, i = 1, 2, \dots, n\}.\end{aligned}$$

is n -dimensional vector space.

Definition 1.3. Let \mathbb{E} be non-empty set. The function

$$d : \mathbb{E} \times \mathbb{E} \rightarrow \mathbb{R}_+ \tag{1.1}$$

$$(u, v) \mapsto d(u, v) \tag{1.2}$$

is said to be distance if it satisfies the following statements:

- (i.) for all $u, v \in \mathbb{E}$, $d(u, v) = 0 \iff u = v$.
- (i.) Symmetry: for every $u, v \in \mathbb{E}$, $d(u, v) = d(v, u)$.

(iii.) *Positivity:* for every $u, v \in \mathbb{E}$, $d(u, v) \geq 0$.

(iv.) *The triangle inequality:* for every $u, v, w \in \mathbb{E}$, $d(u, w) \leq d(u, v) + d(v, w)$.

Definition 1.4. A metric space is a pair (\mathbb{E}, d) where $\mathbb{E} \neq \emptyset$ is a vector space and d is a distance (metric) on \mathbb{E} .

Example 1.5. Let $\mathbb{E} = \mathbb{R}^n$, $x = (x_1, x_2, \dots, x_n)$ and $y = (y_1, y_2, \dots, y_n)$. The following functions

$$1) d_1(x, y) = \sum_{i=1}^n |x_i - y_i|, \quad \text{for all } x, y \in \mathbb{R}^n. \text{ Manhattan metric,}$$

$$2) d_2(x, y) = \left(\sum_{i=1}^n |x_i - y_i|^2 \right)^{\frac{1}{2}}, \quad \text{for all } x, y \in \mathbb{R}^n. \text{ Euclidian metric,}$$

$$3) \text{ Let } p > 1, d_p(x, y) = \left(\sum_{i=1}^n |x_i - y_i|^p \right)^{\frac{1}{p}}, \quad \text{for all } x, y \in \mathbb{R}^n. \text{ Minkowski metric,}$$

are metrics on \mathbb{R}^n .

Example 1.6. Let $\mathbb{E} = \mathbb{R}^2$. The function $d : \mathbb{R}^2 \times \mathbb{R}^2 \rightarrow \mathbb{R}_+$ with

$$d(x, y) = \sqrt{(x_1 - y_1)^2 + (x_2 - y_2)^2}, \quad \text{for all } x, y \in \mathbb{R}^2,$$

is a metric on \mathbb{R}^2 . It is known as the *Euclidean metric* on \mathbb{R}^2 . We denote this metric by d_2 . Indeed, we can readily observe that the axiomes (i.)-(iii.) hold. So, we need only to verify the axiome (iv.). For any $x, y, z \in \mathbb{R}^2$, we have

$$\begin{aligned} d(x, y) &= \sqrt{(x_1 - y_1)^2 + (x_2 - y_2)^2}, \\ d(x, z) &= \sqrt{(x_1 - z_1)^2 + (x_2 - z_2)^2}, \\ d(z, y) &= \sqrt{(z_1 - y_1)^2 + (z_2 - y_2)^2}. \end{aligned}$$

Denote

$$a_1 = x_1 - z_1, \quad a_2 = x_2 - z_2, \quad b_1 = z_1 - y_1, \quad \text{and} \quad b_2 = z_2 - y_2.$$

Then, it yields

$$\begin{aligned} d(x, y) &= \sqrt{(a_1 + b_1)^2 + (a_2 + b_2)^2} \\ &= \sqrt{\sum_{k=1}^2 (a_k + b_k)^2}, \end{aligned}$$

$$d(x, z) = \sqrt{\sum_{k=1}^2 a_k^2}, \quad \text{and} \quad d(z, y) = \sqrt{\sum_{k=1}^2 b_k^2}.$$

On the other hand, by Minkowski's inequality, we have

$$\sqrt{\sum_{k=1}^2 (a_k + b_k)^2} \leq \sqrt{\sum_{k=1}^2 a_k^2} + \sqrt{\sum_{k=1}^2 b_k^2}.$$

Hence, we obtain

$$d(x, y) \leq d(x, z) + d(z, y), \quad \text{for all } x, y, z \in \mathbb{R}^2.$$

Exercise 1.7. Show that $d_p(x, y)$ given by (1.5) is metric on \mathbb{R}^n

Definition 1.8. Let \mathbb{E} be a real vector space. A function

$$\begin{aligned} \|\cdot\| : \mathbb{E} &\rightarrow \mathbb{R} \\ u &\mapsto \|u\| \end{aligned}$$

is called a norm on \mathbb{E} if it satisfies the following properties:

- (i.) For all $u \in \mathbb{E}$, $\|u\| \geq 0$. (Positivity)
- (ii.) For all $u \in \mathbb{E}$, $\|u\| = 0 \iff u = 0$. (Definiteness)
- (iii.) For all $u \in \mathbb{E}$, and $\lambda \in \mathbb{R}$, $\|\lambda u\| = |\lambda| \|u\|$. (Homogeneity)
- (iv.) For all $u, v \in \mathbb{E}$, $\|u + v\| \leq \|u\| + \|v\|$. (Triangle inequality)

Definition 1.9. A normed space is a pair $(\mathbb{E}, \|\cdot\|)$, where $\mathbb{E} \neq \emptyset$ is a vector space and $\|\cdot\|$ is a norm on \mathbb{E} .

Example 1.10. Let $\mathbb{E} = \mathbb{R}^n$ and $x = (x_1, x_2, \dots, x_n) \in \mathbb{R}^n$. The following functions:

- 1.) $\|x\|_1 = \sum_{i=1}^n |x_i|$,
- 2.) $\|x\|_2 = \left(\sum_{i=1}^n |x_i|^2 \right)^{\frac{1}{2}}$. Euclidean norm,
- 3.) $\|x\|_p = \left(\sum_{i=1}^n |x_i|^p \right)^{\frac{1}{p}}$,
- 4.) $\|x\|_\infty = \max_{1 \leq i \leq n} |x_i|$

are norms on \mathbb{R}^n .

Exercise 1.11. Show that $\|\cdot\|_2$ verify the axioms of norm on \mathbb{R}^n .

It is clearly to observe that the function $\|x\|_2$, $x \in \mathbb{R}^n$ is verifying the three conditions (i.), (ii.) and (iii.) provided in Definition 1.8. So, we only need to verify the last condition (iv.). Let $x, y \in \mathbb{R}^n$, i.e, $x = (x_1, x_2, \dots, x_n)$ and $y = (y_1, y_2, \dots, y_n)$. Then, we have

$$\begin{aligned} \|x + y\|_2 &= \|x_1 + y_1, x_2 + y_2, \dots, x_n + y_n\|_2 \\ &= \left(\sum_{i=1}^n (x_i + y_i)^2 \right)^{\frac{1}{2}} \end{aligned}$$

Now, by Minkowski's inequality, we have

$$\left(\sum_{i=1}^n (x_i + y_i)^2 \right)^{\frac{1}{2}} \leq \left(\sum_{i=1}^n |x_i|^2 \right)^{\frac{1}{2}} + \left(\sum_{i=1}^n |y_i|^2 \right)^{\frac{1}{2}} \tag{1.3}$$

$$= \|x\|_2 + \|y\|_2. \tag{1.4}$$

Therefore, we have

$$\|x + y\|_2 \leq \|x\|_2 + \|y\|_2. \tag{1.5}$$

Exercise 1.12. Show that for any $x, y \in \mathbb{R}^n$, the following inequality

$$\left| \|x\| - \|y\| \right| \leq \|x - y\|$$

is hold.

Definition 1.13. Let \mathbb{E} be a real vector space. Two norms $\|\cdot\|$ and $\|\|\cdot\|\|$ on \mathbb{E} are said to be equivalent if there exists $c_1, c_2 > 0$ such that

$$c_1\|u\| \leq \|\|u\|\| \leq c_2\|u\|,$$

for any $u \in \mathbb{E}$.

- All norms of \mathbb{R}^n are equivalent.

Exercise 1.14. Show that $\|\cdot\|_2$ and $\|\cdot\|_\infty$ are equivalent norms on \mathbb{R}^n .

I have to add the proof of Hölder and Minkowski inequalities

2 Open/closed set

Definition 2.1. An open ball centred at the point $a \in \mathbb{R}^n$ of radius $\delta > 0$ is the set

$$B(a, \delta) = \{x \in \mathbb{R}^n \quad : \quad \|x - a\| < \delta\}. \quad (1.6)$$

Thus $B(a, \delta)$ is consisting of all points of \mathbb{R}^n that lie within a sphere of radius δ centred on the point a .

Definition 2.2. A closed ball centred at $a \in \mathbb{R}^n$ of radius $\delta > 0$ is the set

$$\bar{B}(a, \delta) = \{x \in \mathbb{R}^n \quad : \quad \|x - a\| \leq \delta\}. \quad (1.7)$$

The open ball $B(a, \delta)$ is bounded by the sphere centred at the point a of radius δ . This sphere is defined by

$$B(a, \delta) = \{x \in \mathbb{R}^n \quad : \quad \|x - a\| = \delta\}. \quad (1.8)$$

Example 2.3. Let $x = (x_1, x_2) \in \mathbb{R}^2$ and $a = (0, 0)$. Then, we have

$$\begin{aligned} B(a, 1) &= \{x \in \mathbb{R}^2 \quad : \quad \|x\|_2 < 1\} \\ &= \{x \in \mathbb{R}^2 \quad : \quad \sqrt{x_1^2 + x_2^2} < 1\} \\ &= \{x \in \mathbb{R}^2 \quad : \quad x_1^2 + x_2^2 < 1\}, \end{aligned}$$

which consists of all points on the interior of the unit circle $x_1^2 + x_2^2 = 1$. (the circle is not included in its interior)

Example 2.4. Let $x = (x_1, x_2) \in \mathbb{R}^2$ and $a = (1, 1)$. Then, we have

$$\begin{aligned} B(a, 3/4) &= \left\{ x \in \mathbb{R}^2 \quad : \quad \|x - a\|_1 \leq \frac{3}{4} \right\} \\ &= \left\{ x \in \mathbb{R}^2 \quad : \quad |x_1 - 1| + |x_2 - 1| \leq \frac{3}{4} \right\}, \end{aligned}$$

and hence, $B(a, \frac{3}{4})$ consists of those points in the square centred at the point $(1, 1)$, with vertical and horizontal radius of $\frac{3}{4}$.

Definition 2.5. A set $A \subset \mathbb{R}^n$ is said to be open if for each $a \in A$, there exists $\delta > 0$ such that $B(a, \delta) \subset A$.

Definition 2.6. A set A is said to be closed if and only if its complement A^c is open.

Exercise 2.7. Let $\gamma \in \mathbb{R}$, and

$$S = \{(x, y, z) \in \mathbb{R}^3 : z > \gamma\}.$$

Show that S is an open set of \mathbb{R}^3 .

Let $p = (a, b, c) \in S$, then $c > \gamma$. Moreover, let $\delta > 0$, and $\|(x, y, z) - (a, b, c)\| < \delta$. Then, $|x - a| + |y - b| + |z - c| < \delta$. By taking $\delta = c - \gamma$, it yields that $z > \gamma$, which implies that $B(p, \delta) \subset S$, and hence, S is an open set in \mathbb{R}^3 .

3 Closure, interior, boundary,

Definition 3.1. A point a is an accumulation point of a set $A \subset \mathbb{R}^n$, if every open set containing a (neighbourhood of a) contains many points of A , i.e., for all $\delta > 0$

$$B(a, \delta) \cap A \setminus \{a\} \neq \emptyset.$$

- It is possible but not necessary that $a \in A$.
- The set of all accumulation points of the set A is denoted by A' .
- A is closed if $A' \subset A$.

Definition 3.2. The closure of a set $A \subset \mathbb{R}^n$ is the set $\bar{A} = A \cup A'$

- If $a \in \bar{A}$, then the point a is said to be adherent point of A .
- $a \in \bar{A}$ if and only if for all $\delta > 0$, $B(a, \delta) \cap A \neq \emptyset$.
- A is closed if and only if $\bar{A} = A$.

Definition 3.3. Let $A \subseteq \mathbb{R}^n$. A point $a \in A$ is said to be interior point of A , if there exists $\delta > 0$ such that $B(a, \delta) \subset A$.

- A set of all interior points of the set A is denoted by A° .

Chapter 2

Function of several variable

1 Functions of several variables

Definition 1.1. A real valued function of n -variables is a function $f : D \rightarrow \mathbb{R}$, where the domain D is a subset of \mathbb{R}^n . So, for any $(x_1, x_2, \dots, x_n) \in D$, the value of f is a real number $f(x_1, x_2, \dots, x_n)$.

Example 1.2. The volume of a cylinder is function of two variable $V(r, h) = \pi r^2 h$, where r is the radius and h is the height of the cylinder. Notice that, if $r = 2$ and $h = \frac{15}{2}$, then, we have $V(r, h) = 30\pi \in \mathbb{R}$.

• • If we deal with a function of two independent variables, we typically denote them as x and y . In this case, we can visualize the domain of this function as a region in the xy -plane. Moreover, if f is a function of three independent variables, we denote them as x , y , and z , and hence we visualize its domain as a region in space.

Note that to evaluate functions defined by explicit formulas, we substitute the values of the independent variables in the formula and calculate the corresponding value of the dependent variable.

Definition 1.3. The domain of a function f of n -variables, denoted D_f , is the largest set of \mathbb{R}^n in which we can evaluate the function f .

Example 1.4. Given

$$f(x, y) = \sqrt{y - x^2}.$$

Determine and visualize the domain of $f(x, y)$.

The function f is defined at (x, y) (i.e., the evaluation of f at (x, y) is a real number) if the quantity under the square is non-negative, that is, $y - x^2 \geq 0$. Therefore, we find

$$D_f := \{(x, y) \in \mathbb{R}^2 : y \geq x^2\},$$

and it can be visualized as follows:

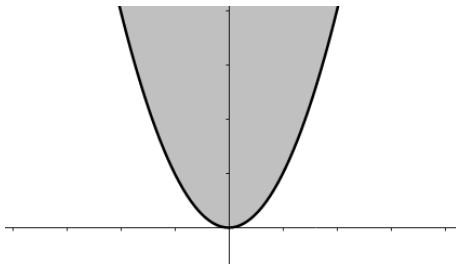

Example 1.5. Find and visualize the domain of $f(x, y) = \ln(1 - x^2 - y^2)$.

The function f is well-defined if the quantity $1 - x^2 - y^2 > 0$, or equivalently $x^2 + y^2 < 1$, and hence

$$D_f := \{(x, y) \in \mathbb{R}^2 : x^2 + y^2 < 1\},$$

which is an open unit ball of \mathbb{R}^2 . Thus, it can be visualized as follows:

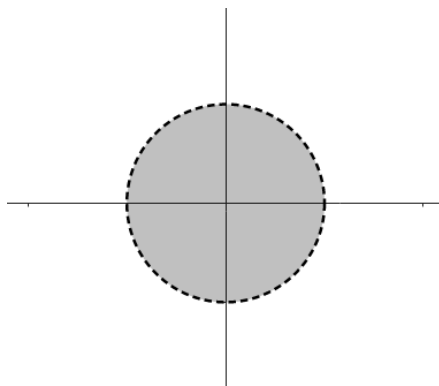

Example 1.6. Determine the domain of the function f defined by:

$$f(x, y, z) = x^2 \sqrt{z - 2x^2 - 4y^2}.$$

The square root is well-defined only for non-negative quantities. Thus, f is defined when $z - 2x^2 - 4y^2 \geq 0$, which means

$$D_f := \{(x, y, z) \in \mathbb{R}^3 : z \geq 2(x^2 + 2y^2)\}.$$

Definition 1.7. The graph of the function of two variables $f(x, y)$ with domain D is the set of points (x, y, z) in space, where $z = f(x, y)$ and $(x, y) \in D$.

Example 1.8. Determine the domain of $f(x, y) = \sqrt{9 - x^2 - y^2}$ and sketch its graph.

The function f is defined when the quantity under the square root is non-negative, (i.e., $9 - x^2 - y^2 \geq 0$), which is equivalent to $x^2 + y^2 \leq 9$. Therefore, the domain of f is the circle centred on $(0, 0)$ with radius $r = 3$. That is

$$D_f := \{(x, y) \in \mathbb{R}^2 : x^2 + y^2 \leq 9\}.$$

The graph of $f(x, y)$ is as follows:

Example 1.9. Sketch the graph of $f : \mathbb{R}^2 \rightarrow \mathbb{R}$ defined by

$$f(x, y) = x^2 - y^2.$$

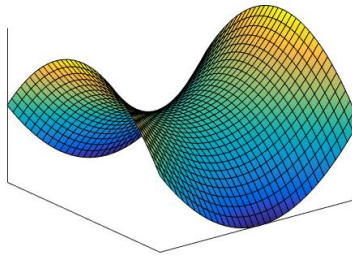

Figure 2.1: Graph of: $f(x, y) = x^2 - y^2$

2 Level curves

Definition 2.1. Let $D \subseteq \mathbb{R}^n$ be the domain of a function $f : D \rightarrow \mathbb{R}$. Then, for any $k \in \mathbb{R}$, the level set of f at level k is defined by

$$C_k(f) := \{x \in D : f(x) = k\}.$$

Remark 2.2. If $n = 2$ we generally have (level curves). If $n = 3$ we have (level surfaces).

Example 2.3. Consider $f : \mathbb{R}^2 \rightarrow \mathbb{R}$ defined by

$$f(x, y) = 5x^2 + y^2 - 1.$$

Determine and sketch the level curves of f .

By definition the level curves of f are given by the set

$$\begin{aligned} C_k(f) &= \{(x, y) \in \mathbb{R}^2 \in D : f(x, y) = k\} \\ &= \{(x, y) \in \mathbb{R}^2 \in D : 5x^2 + y^2 - 1 = k\}. \end{aligned}$$

Therefore, for $k = 0, 1, 2, 3, 4$, it yields

$$\begin{aligned} 5x^2 + y^2 &= 1, \\ 5x^2 + y^2 &= 2, \\ 5x^2 + y^2 &= 3, \\ 5x^2 + y^2 &= 4, \\ 5x^2 + y^2 &= 5, \end{aligned}$$

respectively, which are ellipses and are visualized as follows:

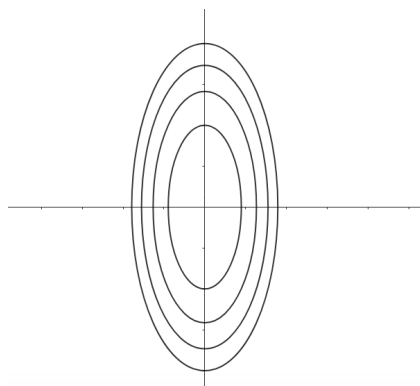

3 Exercises

Exercise 3.1. Determine and visualize the domain of each of the following functions:

- | | |
|---|---|
| (a) $\frac{\sqrt{x^2 - y}}{\sqrt{y}}$, | (b) $\frac{\ln y}{\sqrt{x - y}}$, |
| (c) $\sum_{n=0}^{\infty} \left(\frac{x}{y}\right)^n$, | (d) $\frac{\ln(1 + x^2)}{xy}$, |
| (e) $\arccos(x + y)$, | (f) $\arcsin(2 - x^2 - y)$, |
| (g) $y\sqrt{2 - x^2} + \arctan\left(\frac{y}{x}\right)$, | (h) $\sqrt{\sin x + y} + \sqrt{\sin x - y}$, |
| (i) $\frac{\sin(x + y)}{x^2 + 2y^2 - 2x + 1}$, | (j) $\ln(xy)$. |

Solution. (a) The function $f(x, y) = \frac{\sqrt{x^2 - y}}{\sqrt{y}}$ is defined if the quantities under the square are non-negatives (i.e., $x^2 - y \geq 0$ and $y \geq 0$, and further the denominator does not vanish $\sqrt{y} \neq 0$). Thus, we have:

$$D_f := \{(x, y) \in \mathbb{R}^2 : 0 < y \leq x^2\}.$$

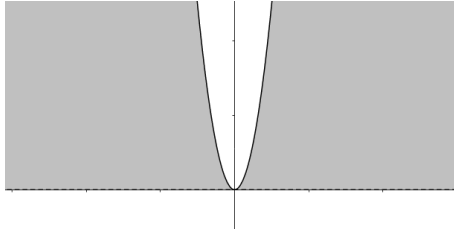

Figure 2.2: Domain of $f(x, y) = \frac{\sqrt{x^2 - y}}{\sqrt{y}}$.

(b) The function $f(x, y) = \frac{\ln y}{\sqrt{x-y}}$ is defined when $\ln y$ exists (i.e., $y > 0$), and $\sqrt{x-y}$ is defined (i.e. $x - y \geq 0$), and the denominator does not vanish, $\sqrt{x-y} \neq 0$. Therefore, it yields

$$D_f := \{(x, y) \in \mathbb{R}^2 : x > y > 0\}.$$

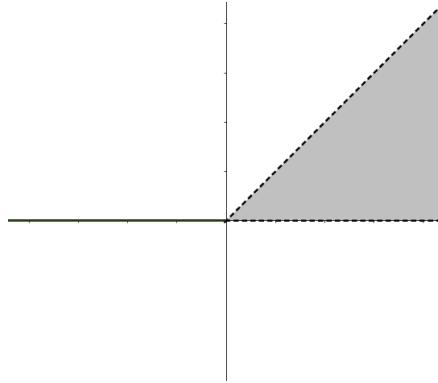

Figure 2.3: Domain of $f(x, y) = \frac{\ln y}{\sqrt{x-y}}$.

(c) Notice that $f(x, y) = \sum_{n=0}^{\infty} \left(\frac{x}{y}\right)^n$ is expressed as the sum of the geometric sequence of common ratio $r = \frac{x}{y}$. Therefore, the requirement of f to be defined is that $|r| < 1$, which means $|\frac{x}{y}| < 1$. Hence, we have

$$D_f := \{(x, y) \in \mathbb{R}^2 : |x| < |y|\}.$$

(d) It is clear that $\ln(1+x^2)$ is always defined. Hence, $f(x, y) = \frac{\ln(1+x^2)}{xy}$ is well-defined if the denominator does not vanish, (i.e., $xy \neq 0$). So, we have

$$D_f := \{(x, y) \in \mathbb{R}^2 : xy \neq 0\}.$$

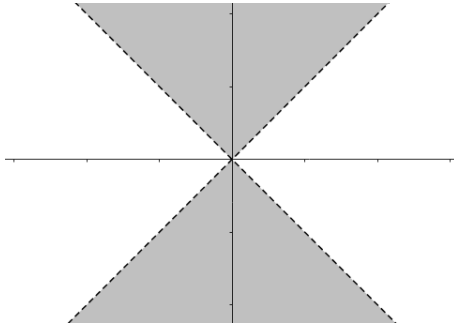

Figure 2.4: Domain of: $f(x, y) = \sum_{n=0}^{\infty} \left(\frac{x}{y}\right)^n$.



Figure 2.5: Domain of: $f(x, y) = \frac{\ln(1+x^2)}{xy}$.

(e) The function $f(x, y) = \arccos(x + y)$ is defined when the quantity $x + y$ is between -1 and 1 , (i.e.; $-1 \leq x + y \leq 1$). That is f is well-defined if $|x + y| \leq 1$. Hence, we obtain

$$D_f := \{(x, y) \in \mathbb{R}^2 : |x + y| \leq 1\}.$$

(f) The function $f(x, y) = \arcsin(2 - x^2 - y)$ is defined at (x, y) if $-1 \leq 2 - x^2 - y \leq 1$, which is equivalent to

$$D_f := \{(x, y) \in \mathbb{R}^2 : y \leq 3 - x^3 \quad \text{and} \quad y \geq 1 - x^2\}.$$

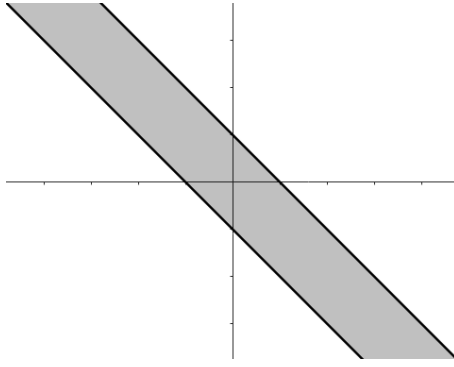

Figure 2.6: Domain of: $f(x, y) = \arccos(x + y)$.

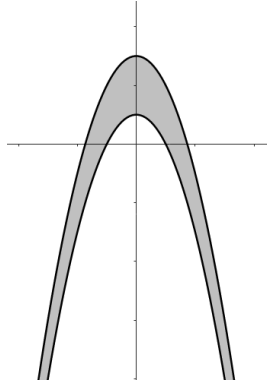

Figure 2.7: Domain of: $f(x, y) = \arcsin(2 - x^2 - y)$

(g) Obviously, the function $f(x, y) = y\sqrt{2 - x^2} + \arcsin\left(\frac{y}{x}\right)$ is defined if $2 - x^2 \geq 0$ and $x \neq 0$, which is equivalently

$$D_f := \{(x, y) \in \mathbb{R}^2 : 0 < x \leq \sqrt{2}\} \cup \{(x, y) \in \mathbb{R}^2 : -\sqrt{2} \leq x < 0\}.$$

(h) Noticing that $f(x, y) = \sqrt{\sin x + y} + \sqrt{\sin x - y}$ is well-defined when both $\sin x - y \geq 0$ and $\sin x + y \geq 0$, which means $-\sin x \leq y \leq \sin x$ such that $\sin x \geq 0$, (i.e., $x \in [2k\pi, \pi + 2k\pi]$, $k \in \mathbb{Z}$, and the domain is

$$D_f = \bigcup_{k \in \mathbb{Z}} \{(x, y) \in \mathbb{R}^2 : x \in [2k\pi, \pi + 2k\pi] \text{ and } |y| \leq \sin x\}.$$

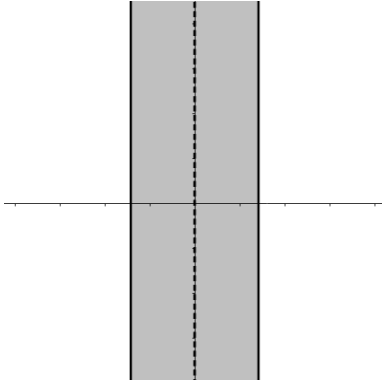

Figure 2.8: Domain of: $f(x, y) = y\sqrt{2 - x^2} + \arcsin\left(\frac{y}{x}\right)$.

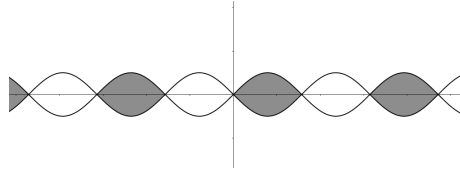

Figure 2.9: Domain of: $f(x, y) = y\sqrt{2 - x^2} + \arcsin\left(\frac{y}{x}\right)$.

(i) The function $f(x, y) = \frac{\sin(x+y)}{x^2+2y^2-2x+1}$ is defined when the denominator does not vanish, (i.e., $x^2 + 2y^2 - 2x + 1 \neq 0$). Notice that

$$x^2 + 2y^2 - 2x + 1 = (x - 1)^2 + 2y^2.$$

Therefore, f is defined for all $(x, y) \neq (1, 0)$. Hence, $D_f = \mathbb{R}^2 \setminus \{(1, 0)\}$.

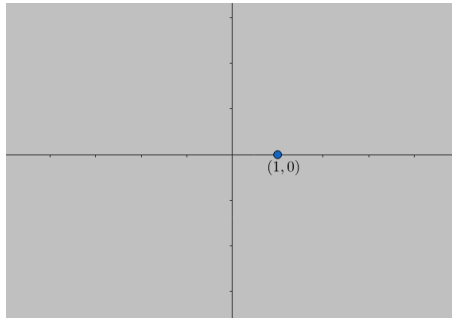

Figure 2.10: Domain of: $f(x, y) = \frac{\sin(x+y)}{x^2+2y^2-2x+1}$.

(j) The function $f(x, y) = \ln(xy)$ is defined at (x, y) if $xy > 0$. This holds true if both x and y have the same sign (i.e. either both positive or both negative). Therefore, the domain can be presented as follows:

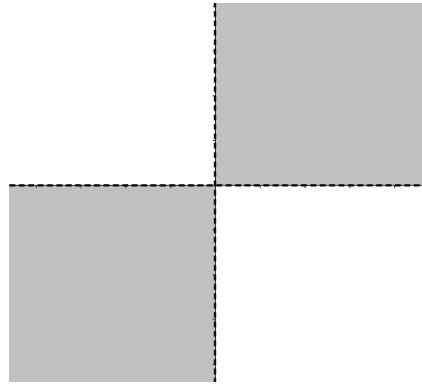

Figure 2.11: Domain of: $f(x, y) = \ln(xy)$.

Exercise 3.2. Find and sketch the level curves for each of the following functions for the given values of the constant k .

- (a) $|x| + |y|$, $k = 1, 2, 3$,
- (b) $x^2 - 2x + y^2$, $k = 1, 2, 3$,
- (c) $\ln(1 - x^2 + y)$, $k = -1, 0, 1$,
- (d) $1 - |x| - |y|$, $k \in \mathbb{R}$,
- (e) $6 - 5x - 3y$, $k = -6, 0, 6$.

(a) Notice that f is defined on all of \mathbb{R}^2 . Therefore, the level curves of the function $f : \mathbb{R}^2 \rightarrow \mathbb{R}$ are given by the equation

$$|x| + |y| = k.$$

Here, we need to consider the following different cases :

- (i) If $x \geq 0$ and $y \geq 0$, then $x + y = k \Rightarrow y = -x + k$,
- (ii) If $x \geq 0$ and $y \leq 0$, then $x - y = k \Rightarrow y = x - k$,
- (iii) If $x \leq 0$ and $y \leq 0$, then $-x - y = k \Rightarrow y = -x - k$,
- (iv) If $x \leq 0$ and $y \geq 0$, then $-x + y = k \Rightarrow y = x + k$.

Then, the level curve is the boundaries of the squares of centre $(0, 0)$ and the corners $(\pm k, 0)$ and $(0, \pm k)$.

(b) To determine the level curves of $f(x, y) = x^2 - 2x + y^2$, we solve the following equation:

$$x^2 - 2x + y^2 = k,$$

which is equivalent to

$$(x - 1)^2 + y^2 = 1 + k.$$

In this case, the level curves are circles of centre $(1, 0)$ with radius $\sqrt{1 + k}$.

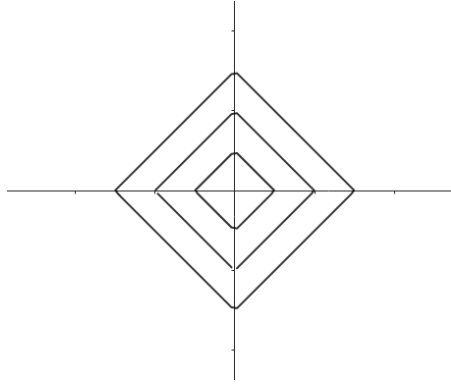

Figure 2.12: Level curves of: $f(x, y) = |x| + |y|$.

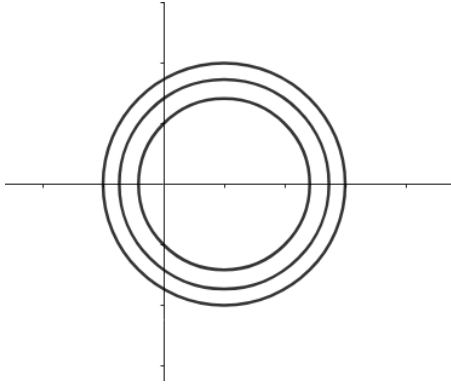

Figure 2.13: Level curves of: $f(x, y) = x^2 - 2x + y^2$.

(e) Firstly, $f(x, y) = \ln(1 - x^2 - y)$ is defined when $1 - x^2 - y > 0$, which implies that

$$D_f := \{(x, y) \in \mathbb{R}^2 : y < x^2 - 1\}.$$

Next, to determine the level curves of f , we solve the equation $f(x, y) = k$. That is,

$$\ln(1 - x^2 - y) = k,$$

which implies directly that

$$y = x^2 + e^k - 1.$$

Therefore, the level curves are the parabolas of equations $y = ax^2 + bx + c$, with $a = 1$, $b = 0$ and $c = e^k - 1$.

(d) The level curves of $f(x, y)$ are given by the equation:

$$1 - |x| - |y| = k,$$

so that

$$|y| = 1 - k - |x|, \quad \text{with } 0 \leq |x| \leq 1 - k.$$

Hence, f admit level curves only when $k \leq 1$. Therefore, we get for the level curves

$$y = \pm(1 - k - |x|), \quad \text{with } k - 1 \leq x \leq 1 - k.$$

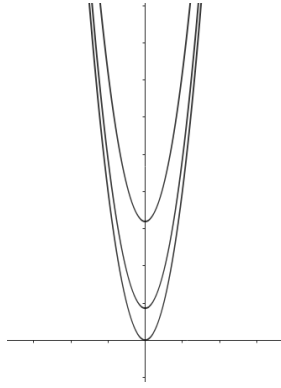
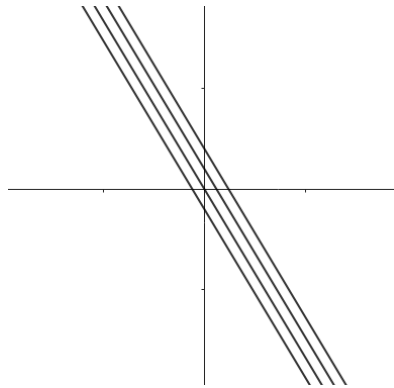

Figure 2.14: Level curves of: $f(x, y) = \ln(1 - x^2 - y)$.

(e) The level curves of the function $f(x, y) = 6 - 5x - 6y$ are given by the equation

$$6 - 5x - 2y = k \quad \text{or} \quad 5x + 2y + (6 - k) = 0.$$

Therefore, the level curves of f are the diagonal lines with slope $-\frac{5}{2}$. In particular, the level curves with $k = -6, 0, 6, 12$, are given by the equations $5x + 2y + 12 = 0$, $5x + 2y - 6 = 0$ and $5x + 2y = 0$, respectively.



Chapter 3

Limit and continuity

1 Limit

For the functions of a single variable $f : I \subseteq \mathbb{R} \rightarrow \mathbb{R}$, we know that there are two one-sided limits at x_0 , i.e.,

$$\lim_{x \rightarrow x_0^-} f(x) \quad \text{and} \quad \lim_{x \rightarrow x_0^+} f(x),$$

That is indicating that x can only approach x_0 from one of two directions: the right or the left.

In the case of functions with many variables, the complexity arises due to the existence of an unlimited number of distinct curves that can be used to approach one point from another.

Definition 1.1. Let \mathcal{D} be an open set of \mathbb{R}^n and $f : \mathcal{D} \subseteq \mathbb{R}^n \rightarrow \mathbb{R}$. Let $x_0 \in \mathcal{D} \cup \partial\mathcal{D}$. Then, it is said that the limit of f as x approaches x_0 is ℓ if, for every $\varepsilon > 0$, there exists $\delta > 0$ such that if

$$x \in \mathcal{D} \setminus \{x_0\} \text{ and } \|x - x_0\| < \delta \implies |f(x) - \ell| < \varepsilon. \quad (3.1)$$

In this case, we can write

$$\lim_{x \rightarrow x_0} f(x) = \ell.$$

Example 1.2. Let $f : \mathbb{R}^2 \rightarrow \mathbb{R}$ be defined by $f(x, y) = xy$. Show that

$$\lim_{(x,y) \rightarrow (a,b)} f(x, y) = ab$$

for any point (a, b) .

Show that $\lim_{(x,y) \rightarrow (a,b)} f(x, y) = ab$, it suffice to prove that for every $\varepsilon > 0$, there exists $\delta > 0$ such that

$$\|(x, y) - (a, b)\| < \delta \implies |xy - ab| < \varepsilon.$$

Noting that the distance between (x, y) and (a, b) is given by

$$R = \|(x, y) - (a, b)\| = \sqrt{(x - a)^2 + (y - b)^2}.$$

Therefore, we have

$$|x - a| \leq R, \quad \text{and} \quad |y - b| \leq R.$$

On the other hand, we have

$$\begin{aligned} |xy - ab| &= |(x - a)(y - b) + a(y - b) + b(x - a)| \\ &\leq |x - a||y - b| + |a||y - b| + |b||x - a| \\ &\leq R^2 + (|a| + |b|)R \\ &= R^2 + 2\alpha R \\ &= (R + \alpha)^2 - \alpha^2, \end{aligned}$$

where $\alpha = \frac{1}{2}(|a| + |b|)$. Now, fixing $\varepsilon > 0$ and demand that R is such that

$$(R + \alpha)^2 - \alpha^2 < \varepsilon \quad \implies \quad R < \sqrt{\varepsilon + \alpha^2} - \alpha.$$

Hence, it suffice to choose $\delta = \sqrt{\varepsilon + \alpha^2} - \alpha$.

Example 1.3. Let $f : \mathbb{R}^2 \setminus \{(0, 0)\} \rightarrow \mathbb{R}$ be defined by $f(x, y) = \frac{x^2 y}{x^2 + y^2}$. Show that

$$\lim_{(x, y) \rightarrow (0, 0)} f(x, y) = 0.$$

Here, we need to show that for every $\varepsilon > 0$, there exists $\delta > 0$ such that

$$\|(x, y) - (0, 0)\| < \delta \quad \implies \quad \left| \frac{x^2 y}{x^2 + y^2} - 0 \right| < \varepsilon.$$

We have the distance between (x, y) and $(0, 0)$ is

$$R = \|(x, y) - (0, 0)\| = \sqrt{x^2 + y^2}.$$

Therefore, it yields

$$|x| \leq R, \quad \text{and} \quad |y| \leq R.$$

On the other hand, we have

$$\begin{aligned} \left| \frac{x^2 y}{x^2 + y^2} - 0 \right| &= \frac{x^2 |y|}{x^2 + y^2} \\ &\leq \frac{x^2 + y^2}{x^2 + y^2} |y| \\ &\leq \sqrt{x^2 + y^2} = R, \end{aligned}$$

where we have used the inequalities $|x| = \sqrt{x^2} \leq \sqrt{x^2 + y^2}$ and $|y| = \sqrt{y^2} \leq \sqrt{x^2 + y^2}$ to get the last step. Now, fix $\varepsilon > 0$ and demand that R is such that $R < \varepsilon$. Hence, we can choose $\delta = \varepsilon$.

Properties of the limit:

Theorem 1.4. Let \mathcal{D} be an open set of \mathbb{R}^n and $f, g : \mathcal{D} \rightarrow \mathbb{R}$. Let $x_0 \in \mathcal{D} \cup \partial\mathcal{U}$. Suppose that

$$\lim_{x \rightarrow x_0} f(x) = \ell_f, \quad \text{and} \quad \lim_{x \rightarrow x_0} g(x) = \ell_g.$$

Then, we have

- (i) $\lim_{x \rightarrow x_0} (f \pm g)(x) = \lim_{x \rightarrow x_0} f(x) \pm \lim_{x \rightarrow x_0} g(x) = \ell_f \pm \ell_g,$
- (ii) $\lim_{x \rightarrow x_0} (\alpha \cdot f)(x) = \alpha \cdot \lim_{x \rightarrow x_0} f(x) = \alpha \cdot \ell_f, \alpha \in \mathbb{R},$
- (iii) $\lim_{x \rightarrow x_0} (f \cdot g)(x) = \lim_{x \rightarrow x_0} f(x) \cdot \lim_{x \rightarrow x_0} g(x) = \ell_f \cdot \ell_g,$
- (iv) $\lim_{x \rightarrow x_0} \left(\frac{f}{g} \right)(x) = \frac{\lim_{x \rightarrow x_0} f(x)}{\lim_{x \rightarrow x_0} g(x)} = \frac{\ell_f}{\ell_g},$ if $\ell_g \neq 0.$

Strategies to calculate limit :

A. If the function f is continuous at the limit point, then we have

$$\lim_{x \rightarrow x_0} f(x) = f(x_0).$$

Example 1.5. Let $f : \mathbb{R}^2 \rightarrow \mathbb{R}$ defined by $f(x, y) = x - y^2 + \ln(x^2 + y^2 + 1)$. Then, we have

$$\lim_{(x,y) \rightarrow (0,1)} f(x, y) = f(0, 1) = \ln(2) - 1$$

B. Let g be a continuous function at t_0 . If the function f can be written as a composition $f(x) = g(h(x))$ so that x_0 is a limit point

Example 1.6. Evaluate the following limit

$$\lim_{(x,y) \rightarrow (0,0)} \frac{\cos(xy) - 1}{x^2 + y^2}.$$

We have

$$\frac{\cos(xy) - 1}{x^2 + y^2} = \frac{\cos(xy) - 1}{x^2 y^2} \cdot \frac{x^2 y^2}{x^2 + y^2} \tag{3.2}$$

C. Limits along curve

Definition 1.7. A continuous vector function $\sigma(t) : [a, b] \rightarrow \mathbb{R}^n$ is called a curve in \mathbb{R}^n .

Example 1.8. $\sigma : \mathbb{R} \rightarrow \mathbb{R}^2$ defined by $\sigma(t) = (2t, t + 1)$ is parametric curve in \mathbb{R}^2 .

Definition 1.9 (Limit along curve). Let \mathcal{D} be an open set of \mathbb{R}^n and $f : \mathcal{D} \rightarrow \mathbb{R}$. Suppose there exists a parametric curve $\sigma(t)$, $t_0 \leq t \leq b$, such that $\sigma(t)$ is in \mathcal{D} if $t > t_0$ and $\sigma(t_0) = x_0$. Let $v(t) = f(\sigma(t))$, $t > t_0$ be the value of the function f on the curve $\sigma(t)$. Then, the limit

$$\lim_{t \rightarrow t_0^+} v(t) = \lim_{t \rightarrow t_0^+} f(\sigma(t))$$

is called the limit of f along the curve $\sigma(t)$ (if it exists).

Example 1.10. Consider the function $f(x, y)$ defined as

$$f(x, y) = \frac{3xy}{x^2 + y^2}.$$

Evaluate the limit of $f(x, y)$ when (x, y) approaching the origin $(0, 0)$ along the following curves

- (i) the x -axis,
- (ii) the y axis,
- (iii) the path $y = x$,
- (iv) the curve $y = x^2$.

(i) Notice that along the x -axis we can write

$$\lim_{(x,y) \rightarrow (0,0)} f(x, y) = \lim_{t \rightarrow 0} f(t, 0) = \lim_{t \rightarrow 0} \frac{0}{t^2} = 0.$$

(ii) Approaching the limit along y -axis, implies the following

$$\lim_{(x,y) \rightarrow (0,0)} f(x, y) = \lim_{t \rightarrow 0} f(0, t) = \lim_{t \rightarrow 0} \frac{0}{t^2} = 0.$$

(iii) By approaching the limit of $f(x, y)$ through the curve $y = x$, it yields

$$\lim_{(x,y) \rightarrow (0,0)} f(x, y) = \lim_{t \rightarrow 0} f(t, t) = \lim_{t \rightarrow 0} \frac{3t^2}{2t^2} = \frac{3}{2}.$$

(iv) Along the parabola $y = x^2$, we have

$$\lim_{(x,y) \rightarrow (0,0)} f(x, y) = \lim_{t \rightarrow 0} f(t, t^2) = \lim_{t \rightarrow 0} \frac{3t^3}{t^2 + t^4} = \lim_{t \rightarrow 0} \frac{3t}{1 + t^2} = 0.$$

Theorem 1.11. Let \mathcal{D} be the open set of \mathbb{R}^n and $f : \mathcal{D} \rightarrow \mathbb{R}$. Let $x_0 \in \mathcal{D}$. If

$$\lim_{x \rightarrow x_0} f(x) = \ell,$$

then the limit of f along any curve through x_0 exists and is equal to ℓ .

Remark 1.12. The result is useful to show the limit of f does not exist or to compute that value of the limit if we know in advance that the limit exists. But, it cannot be used to prove that a limit exists since one of the hypotheses of the proposition is that the limit exists.

Therefore, we can establish the following essential criterion for the non-existence of a limit of functions of several variables:

Corollary 1.13. Let \mathcal{D} be the open set of \mathbb{R}^n and $f : \mathcal{D} \rightarrow \mathbb{R}$. Let $x_0 \in \mathcal{D}$. If there exists a curve along which the limit of the function f at the point x_0 does not exist, or there are two curves along which the limits of f at x_0 exist but do not coincide, then $\lim_{x \rightarrow x_0} f(x)$ does not exist.

Example 1.14. Show that the following limit does not exist

$$\lim_{(x,y) \rightarrow (0,0)} \frac{x^2 y^2}{x^2 y^2 + (x - y)^2}.$$

Along the x -axis, we have

$$\lim_{(x,y) \rightarrow (0,0)} f(x, y) = \lim_{t \rightarrow 0} f(t, 0) = \lim_{t \rightarrow 0} \frac{t^2 \cdot 0}{t^2 \cdot 0 + (t - 0)^2} = \lim_{t \rightarrow 0} \frac{0}{t^2} = 0.$$

On the other hand, the limit along the curve $y = x$ is

$$\lim_{(x,y) \rightarrow (0,0)} f(x, y) = \lim_{t \rightarrow 0} f(t, t) = \lim_{t \rightarrow 0} \frac{t^2 \cdot t^2}{t^2 \cdot t^2 + (t - t)^2} = \lim_{t \rightarrow 0} \frac{t^4}{t^4} = 1.$$

The two limits along the different curves do not coincide ($0 \neq 1$), which implies that limit of f at the origin does not exist.

E. Squeeze principle is given by the following:

Theorem 1.15 (Squeeze principle). Let \mathcal{D} be an open set of \mathbb{R} and f, g and $h : \mathcal{D} \rightarrow \mathbb{R}$. If

$$g(x) \leq f(x) \leq h(x), \text{ for all } x \in \mathcal{D} \text{ and } \lim_{x \rightarrow x_0} g(x) = \lim_{x \rightarrow x_0} h(x) = \ell,$$

then, we have

$$\lim_{x \rightarrow x_0} f(x) = \ell.$$

Example 1.16. Show that

$$\lim_{(x,y) \rightarrow (0,0)} f(x,y) = 0, \quad \text{where} \quad \frac{x^2y^2 - 2x^3y}{\sqrt{x^2 + y^2}}.$$

Let $R = \sqrt{x^2 + y^2}$. Then, it yields that $|x| \leq R$ and $|y| \leq R$. Therefore, we could get

$$\begin{aligned} 0 \leq \left| \frac{x^2y^2 - 2x^3y}{\sqrt{x^2 + y^2}} \right| &\leq \frac{x^2y^2 + 2|x|^3|y|}{\sqrt{x^2 + y^2}} \\ &\leq \frac{3R^3}{R} \\ &= 3\sqrt[3]{x^2 + y^2}. \end{aligned}$$

Passing to the limit as (x, y) goes to $(0, 0)$, we find

$$0 \leq \lim_{(x,y) \rightarrow (0,0)} |f(x,y)| \leq \lim_{(x,y) \rightarrow (0,0)} 3\sqrt[3]{x^2 + y^2} = 0$$

Hence, by squeeze principle, $f(x, y)$ must tend to 0 as $(x, y) \rightarrow 0$.

F. polar coordinates: When dealing with functions of two variables, it's often helpful to pass to polar coordinates with aim to reduce the calculation of the limit of a function of two variables to that of the limit of a function of a single variable. Indeed, any point (x, y) of $\mathbb{R}^2 \setminus \{(a, b)\}$ can be expressed by its polar coordinates centered around a point (a, b) as follows:

$$\begin{cases} x = a + r \cos \theta, \\ y = b + r \sin \theta, \end{cases} \quad \text{with } r > 0, \theta \in [0, 2\pi[.$$

where r is the distance between (a, b) and (x, y) . Therefore, we can write

$$\lim_{(x,y) \rightarrow (a,b)} f(x,y) = \lim_{\substack{r \rightarrow 0 \\ \forall \theta}} f(a + r \cos \theta, b + r \sin \theta).$$

Theorem 1.17. If there exists $\ell \in \mathbb{R}$ and a function $\varphi(r)$, $r > 0$ such that in the neighborhood of (a, b) we have

$$|f(a + r \cos \theta, b + r \sin \theta) - \ell| \leq \varphi(r) \xrightarrow{r \rightarrow 0} 0,$$

then, we have

$$\lim_{(x,y) \rightarrow (a,b)} f(x,y) = \ell.$$

Example 1.18. By using polar coordinate, evaluate the following limit or show that does not exist:

$$\lim_{(x,y) \rightarrow (0,0)} \frac{xy^2}{x^2 + y^2}.$$

Consider

$$\begin{cases} x = r \cos \theta, \\ y = r \sin \theta, \end{cases} \quad \text{with } r > 0, \theta \in [0, 2\pi[.$$

Therefore, we get

$$\lim_{(x,y) \rightarrow (0,0)} \frac{xy^2}{x^2 + y^2} = \lim_{\substack{r \rightarrow 0 \\ \forall \theta}} \frac{r^3 \cos \theta \sin^2 \theta}{r^2(\cos^2 \theta + \sin^2 \theta)} = \lim_{\substack{r \rightarrow 0 \\ \forall \theta}} r \cos \theta \sin^2 \theta.$$

Next, we have

$$0 \leq |r \cos \theta \sin^2 \theta| \leq r \xrightarrow{r \rightarrow 0} 0, \quad (\text{since } |\cos \theta \sin^2 \theta| \leq 1).$$

Thus, it yields

$$\lim_{(x,y) \rightarrow (0,0)} \frac{xy^2}{x^2 + y^2} = 0.$$

Example 1.19. Prove that the following limit does not exist:

$$\lim_{(x,y) \rightarrow (0,0)} \frac{x^2 - y^2}{x^2 + y^2}.$$

First method. Along the x -axis, (i.e., $x \rightarrow 0$ and $y = 0$), we have

$$\lim_{(x,y) \rightarrow (0,0)} f(x, y) = \lim_{t \rightarrow 0} f(t, 0) = \lim_{t \rightarrow 0} \frac{t^2}{t^2} = 1.$$

Moreover, by passing through y -axis, (i.e., $x = 0$ and $y \rightarrow 0$), we have

$$\lim_{(x,y) \rightarrow (0,0)} f(x, y) = \lim_{t \rightarrow 0} f(0, t) = \lim_{t \rightarrow 0} -\frac{t^2}{t^2} = -1.$$

Observe that the two limits do not coincide which implies that f does not admit a limit at the origin $(0, 0)$.

Second method. By using the polar coordinates, we can write

$$\lim_{(x,y) \rightarrow (0,0)} f(x, y) = \lim_{\substack{r \rightarrow 0 \\ \forall \theta}} \frac{r^2(\cos^2 \theta - \sin^2 \theta)}{r^2(\cos^2 \theta + \sin^2 \theta)} = \cos(2\theta).$$

Hence, the limit has infinite number of values depending on the choice of θ , which implies that $\lim_{(x,y) \rightarrow (0,0)} f(x, y)$ does not exist at the point $(0, 0)$.

2 Continuity

Definition 2.1. Let \mathcal{D} be an open set of \mathbb{R}^n and let $f : \mathcal{D} \rightarrow \mathbb{R}$. We say that f is continuous at the point $x_0 \in \mathcal{D}$ if

$$\lim_{x \rightarrow x_0} f(x) = f(x_0).$$

The function f is said to be continuous on \mathcal{D} if it is continuous at every point of \mathcal{D} .

Example 2.2. Let $f : \mathbb{R}^2 \rightarrow \mathbb{R}$ be defined by

$$f(x, y) = \begin{cases} \frac{\sin^2(x - y)}{|x| + |y|}, & (x, y) \neq (0, 0), \\ 0, & (x, y) = (0, 0). \end{cases}$$

Then, f is continuous function at the origin.

In order to demonstrate that f is continuous function at the point $(0, 0)$, it suffice to show that

$$\lim_{(x,y) \rightarrow (0,0)} f(x, y) = f(0, 0) = 0.$$

Indeed, we have

$$\begin{aligned} \lim_{(x,y) \rightarrow (0,0)} \frac{\sin^2(x - y)}{|x| + |y|} &= \lim_{(x,y) \rightarrow (0,0)} \frac{(x - y)^2 \sin^2(x - y)}{|x| + |y| (x - y)^2} \\ &= \lim_{(x,y) \rightarrow (0,0)} \frac{(x - y)^2}{|x| + |y|} \cdot \lim_{(x,y) \rightarrow (0,0)} \left[\frac{\sin(x - y)}{(x - y)} \right]^2, \end{aligned}$$

where we have used the fact that $\lim_{t \rightarrow 0} \frac{\sin t}{t} = 1$ to evaluate the second limit. Moreover, we have

$$0 \leq \frac{(x - y)^2}{|x| + |y|} \leq |x - y|.$$

Thus, we have

$$0 \leq \lim_{(x,y) \rightarrow (0,0)} \frac{(x - y)^2}{|x| + |y|} \leq \lim_{(x,y) \rightarrow (0,0)} |x - y| = 0.$$

In conclusion, we have obtained $\lim_{(x,y) \rightarrow (0,0)} \frac{\sin^2(x - y)}{|x| + |y|} = f(0, 0) = 0$. That is, f is continuous at the origin. **Properties of continuous functions:**

The following theorem is a simple consequences of the basic properties of the limit.

Theorem 2.3. Let f and g be continuous functions on an open set $\mathcal{D} \subseteq \mathbb{R}^n$, and $\alpha \in \mathbb{R}$. Then, the following functions are continuous on \mathcal{D} :

- (i) Sums/Differences: $f \pm g$,
- (ii) Constant Multiples: $\alpha \cdot f$,

(iii) *Products:* $f \cdot g$,

(iv) *Quotients:* $\frac{f}{g}$ (as long as $g \neq 0$ on \mathcal{D}).

Definition 2.4. (*Epsilon-Delta definition*) Let \mathcal{D} be an open set of \mathbb{R}^n . We say that the function $f : \mathcal{D} \rightarrow \mathbb{R}$ is continuous at the point $x_0 \in \mathcal{D}$ if for every $\varepsilon > 0$, there exists $\delta > 0$ such that if $\|x - x_0\| < \delta$ for all $x \in \mathcal{D} \setminus \{x_0\}$ implies $|f(x) - f(x_0)| < \varepsilon$.

The function f is said to be continuous on \mathcal{D} if it is continuous at every point of \mathcal{D} .

Example 2.5. Using Epsilon-Delta definition show that $f : \mathbb{R}^2 \rightarrow \mathbb{R}$ defined by

$$f(x, y) = \begin{cases} \frac{x^3 y}{x^2 + y^2} \sin(xy), & (x, y) \neq (0, 0), \\ 0, & (x, y) = (0, 0), \end{cases}$$

is continuous function at the origin.

Given $\varepsilon > 0$, we take $\delta = \sqrt{\varepsilon}$. If $0 < \underbrace{\sqrt{x^2 + y^2}}_{\|\cdot\|_2} < \delta$, then we have

$$\begin{aligned} |f(x, y) - f(0, 0)| &= \left| \frac{x^3 y}{x^2 + y^2} \sin(xy) \right| \\ &\leq \frac{|x|^3 |y|}{x^2 + y^2}, \quad \text{since } |\sin(xy)| \leq 1 \\ &\leq |x| |y|. \end{aligned}$$

Now, noting that $|x| \leq \sqrt{x^2 + y^2}$ and $|y| \leq \sqrt{x^2 + y^2}$. Thus, we obtain

$$|f(x, y) - 0| \leq \sqrt{x^2 + y^2} \sqrt{x^2 + y^2} < \delta^2 = \varepsilon,$$

which implies that $f(x, y)$ is continuous function at the point $(0, 0)$.

3 Exercises

Exercise 3.1. Find the limit of each of the following functions, or state that it does not exist :

$$\begin{array}{ll} (a) \lim_{(x,y) \rightarrow (1,0)} \frac{2y^3}{(x-1)^2 + y^2}, & (b) \lim_{(x,y) \rightarrow (0,0)} \frac{1 - \cos(xy^2)}{x^2 + y^4}, \\ (c) \lim_{(x,y) \rightarrow (0,0)} \frac{\sin x - \sin y}{x - y}, & (d) \lim_{(x,y) \rightarrow (0,0)} \frac{x \ln(1 + x^3)}{y(x^2 + y^2)}, \\ (e) \lim_{(x,y) \rightarrow (0,0)} \frac{x^3 + y^3}{x^2 + y^2}, & (f) \lim_{(x,y) \rightarrow (0,0)} \frac{xy \sin(x + y)}{\sqrt{x^2 + y^2}}, \\ (g) \lim_{(x,y) \rightarrow (0,0)} \frac{xy^3 \cos x}{2x^2 + y^6}, & (h) \lim_{(x,y) \rightarrow (0,0)} \frac{2xy}{x^2 - y^2} \end{array}$$

(a) By employing the polar coordinates:

$$\begin{cases} x = 1 + r \cos \theta, \\ y = r \sin \theta, \end{cases}$$

we may get

$$\lim_{(x,y) \rightarrow (1,0)} \frac{2y^3}{(x-1)^2 + y^2} = \lim_{\substack{r \rightarrow 0 \\ \forall \theta}} \frac{3r^3 \sin^3 \theta}{r^2(\cos^2 \theta + \sin^2 \theta)} = \lim_{\substack{r \rightarrow 0 \\ \forall \theta}} 3r \sin^2 \theta.$$

Next, it is obviously to observe that

$$0 \leq |3r \sin^2 \theta| \leq 3r \xrightarrow{r \rightarrow 0} 0.$$

Thus, we can conclude that

$$\lim_{(x,y) \rightarrow (1,0)} \frac{2y^3}{(x-1)^2 + y^2} = 0.$$

(b) In this case, we will evaluate the limit of the function along different paths (curves) to see if the limit exists. Therefore, along the curve $x = y^2$, we have

$$\lim_{(x,y) \rightarrow (0,0)} f(x, y) = \lim_{t \rightarrow 0} f(t^2, t) = \lim_{t \rightarrow 0} \frac{1 - \cos t^4}{2t^4} = \frac{1}{2} \lim_{t \rightarrow 0} \frac{1 - \cos t^4}{t^4} \xrightarrow{\frac{1}{2}} \frac{1}{4}.$$

Whereas, along x -axis, (i.e., $x \rightarrow 0, y = 0$), it yields the following

$$\lim_{(x,y) \rightarrow (0,0)} f(x, y) = \lim_{t \rightarrow 0} f(t, 0) = \lim_{t \rightarrow 0} \frac{0}{t^2} = 0.$$

The two limits do not coincide, which leads to conclude that the limit of $f(x, y)$ does not exist at the point $(0, 0)$.

(c) For all $(x, y) \in \mathbb{R}^2$, we have

$$\sin x - \sin y = 2 \cos \left(\frac{x+y}{2} \right) \sin \left(\frac{x-y}{2} \right).$$

Then, it results

$$\lim_{(x,y) \rightarrow (0,0)} \frac{\sin x - \sin y}{x - y} = \lim_{(x,y) \rightarrow (0,0)} \cos \left(\frac{x+y}{2} \right) \cdot \lim_{(x,y) \rightarrow (0,0)} \frac{\sin \left(\frac{x-y}{2} \right)}{\frac{x-y}{2}} = 1.$$

In the second limit, we put $t = \frac{x-y}{2}$, then $t \rightarrow 0$ when $(x, y) \rightarrow (0, 0)$. Thus, it results

$$\lim_{t \rightarrow 0} \frac{\sin t}{t} = 1.$$

(d) By evaluating the limit of $f(x, y)$ along the line $y = x$, we obtain

$$\begin{aligned} \lim_{(x,y) \rightarrow (0,0)} f(x, y) &= \lim_{t \rightarrow 0} f(t, t) = \lim_{t \rightarrow 0} \frac{t \ln(1 + t^3)}{2t^3} \\ &= \frac{1}{2} \lim_{t \rightarrow 0} \frac{\ln(1 + t^3)}{t^3} \cdot \lim_{t \rightarrow 0} t \\ &= 0 \end{aligned}$$

However, passing through the parabola $y = x^2$, we get

$$\begin{aligned} \lim_{(x,y) \rightarrow (0,0)} f(x,y) &= \lim_{t \rightarrow 0} f(t, t^2) = \lim_{t \rightarrow 0} \frac{\ln(1+t^3)}{t^3(1+t^2)} \\ &= \lim_{t \rightarrow 0} \frac{\ln(1+t^3)}{t^3} \cdot \lim_{t \rightarrow 0} \frac{1}{1+t^2} \\ &= 1. \end{aligned}$$

Observe that the two limits are different, and hence the limit of f at the origin does not exist.

(e) We have

$$\begin{aligned} 0 \leq \left| \frac{x^3 + y^3}{x^2 + y^2} \right| &= \frac{|x+y||x^2 - xy + y^2|}{x^2 + y^2} \\ &\leq |x+y| \frac{x^2 + y^2 + |xy|}{x^2 + y^2} \\ &\leq \frac{3}{2}|x+y| \cdot \frac{x^2 + y^2}{x^2 + y^2}, \end{aligned}$$

where we have used $|xy| \leq \frac{1}{2}(x^2 + y^2)$ to obtain the last step. Now, by passing to the limit as $(x, y) \rightarrow (0, 0)$, we find

$$0 \leq \lim_{(x,y) \rightarrow (0,0)} \left| \frac{x^3 + y^3}{x^2 + y^2} \right| \leq \frac{3}{2} \lim_{(x,y) \rightarrow (0,0)} |x+y|.$$

Hence, by squeeze principle we have $\lim_{(x,y) \rightarrow (0,0)} f(x,y) = 0$.

(f) We have

$$\begin{aligned} \lim_{(x,y) \rightarrow (0,0)} \frac{xy \sin(x+y)}{\sqrt{x^2 + y^2}} &= \lim_{(x,y) \rightarrow (0,0)} \frac{xy(x+y)}{\sqrt{x^2 + y^2}} \cdot \frac{\sin(x+y)}{x+y} \\ &= \lim_{(x,y) \rightarrow (0,0)} \frac{xy(x+y)}{\sqrt{x^2 + y^2}} \cdot \lim_{(x,y) \rightarrow (0,0)} \frac{\sin(x+y)}{x+y}. \end{aligned}$$

Now, we move to evaluate the first limit. We have

$$\begin{aligned} \left| \frac{xy(x+y)}{\sqrt{x^2 + y^2}} \right| &= |x+y| \frac{|xy|}{\sqrt{x^2 + y^2}} \\ &\leq x^2 + y^2, \end{aligned}$$

where we have used $|xy| \leq \frac{1}{2}(x^2 + y^2)$ and $|x+y| \leq 2\sqrt{x^2 + y^2}$. Next, by passing to the limit as (x, y) approaches $(0, 0)$ we find

$$0 \leq \lim_{(x,y) \rightarrow (0,0)} \left| \frac{xy(x+y)}{\sqrt{x^2 + y^2}} \right| \leq \lim_{(x,y) \rightarrow (0,0)} (x^2 + y^2).$$

Thus, by squeeze principle, we have $\lim_{(x,y) \rightarrow (0,0)} \frac{xy(x+y)}{\sqrt{x^2 + y^2}} = 0$. Consequently, it yields that

$$\lim_{(x,y) \rightarrow (0,0)} \frac{xy \sin(x+y)}{\sqrt{x^2 + y^2}} = 0.$$

(g) Let's approach the limit along the x -axis, (i.e., $x \rightarrow 0$, $y = 0$), so that

$$\lim_{(x,y) \rightarrow (0,0)} f(x,y) = \lim_{t \rightarrow 0} f(t,0) = \lim_{t \rightarrow 0} \frac{0}{2t^2} = 0.$$

Next, by approaching along the curve $x = y^2$, it yields the following

$$\lim_{(x,y) \rightarrow (0,0)} f(x,y) = \lim_{t \rightarrow 0} f(t^3, t) = \lim_{t \rightarrow 0} \frac{\cos t^3}{3} = \frac{1}{3}.$$

Obviously ($0 \neq \frac{1}{3}$), so that the limit of f at the point $(0,0)$ does not exist.

(h) We will choose two different sequences that both tend to $(0,0)$, but for which the function $f(x,y) = \frac{2xy}{x^2+y^2}$ approaches different limits. So, let us take

$$(x_n, y_n) = \left(\frac{1}{n}, 0\right) \quad \text{and} \quad (\bar{x}_n, \bar{y}_n) = \left(\frac{1}{n}, \frac{1}{n}\right)$$

Note that both sequences approach $(0,0)$ when $n \rightarrow \infty$. Therefore, we have

$$\lim_{(x,y) \rightarrow (0,0)} f(x,y) = \lim_{n \rightarrow \infty} f(x_n, y_n) = \lim_{n \rightarrow \infty} \frac{0}{\frac{1}{n^2} + 0} = 0,$$

and

$$\lim_{(x,y) \rightarrow (0,0)} f(x,y) = \lim_{n \rightarrow \infty} f(\bar{x}_n, \bar{y}_n) = \lim_{n \rightarrow \infty} \frac{\frac{2}{n^2}}{\frac{1}{n^2} + \frac{1}{n^2}} = 1.$$

Observe that the two limits are not equal $0 \neq 1$. Therefore, the function $f(x,y)$ does not have a limit at a point $(0,0)$.

Exercise 3.2. Consider

$$f(x,y) = \begin{cases} \frac{xy^3}{x^2 + 2y^2} \cos(xy), & (x,y) \neq (0,0), \\ 0, & (x,y) = (0,0), \end{cases}$$

Show that f is continuous function on all of \mathbb{R}^2 .

Solution. Notice that for all $(x,y) \neq 0$, the function f is a quotient of two continuous functions $xy^3 \cos(xy)$ and $x^2 + 2y^2$ and the denominator does not vanish there.

Next, we study the continuity of the function f at the point $(0,0)$. To this end, we need to show that the following limit exists and is equal $f(0,0)$, i.e.,

$$\lim_{(x,y) \rightarrow (0,0)} \frac{xy^3}{x^2 + 2y^2} \cos(xy) = f(0,0) = 0.$$

We have

$$\begin{aligned} 0 \leq \left| \frac{xy^3}{x^2 + 2y^2} \cos(xy) \right| &\leq \frac{|xy^3|}{x^2 + 2y^2}, \quad \text{since } |\cos(xy)| \leq 1 \\ &\leq y^2 \frac{|x||y|}{x^2 + y^2}, \end{aligned}$$

where we have used the fact that $x^2 + 2y^2 \geq x^2 + y^2$ in the last step. On the other hand, by using $|x| = \sqrt{x^2} \leq \sqrt{x^2 + y^2}$ and $|y| = \sqrt{y^2} \leq \sqrt{x^2 + y^2}$, we can obtain

$$\begin{aligned} 0 \leq \lim_{(x,y) \rightarrow (0,0)} |f(x,y)| &\leq \lim_{(x,y) \rightarrow (0,0)} y^2 \cdot \frac{\sqrt{x^2 + y^2} \sqrt{x^2 + y^2}}{x^2 + y^2} \overset{1}{=} \\ &= \lim_{(x,y) \rightarrow (0,0)} y^2 \\ &= 0. \end{aligned}$$

Therefore, we obtain $\lim_{(x,y) \rightarrow (0,0)} f(x,y) = 0 = f(0,0)$, and hence f is continuous function at the point $(0,0)$. In conclusion, f is continuous function on all of \mathbb{R}^2 .

Exercise 3.3. Consider $f : \mathbb{R}^2 \rightarrow \mathbb{R}$ defined by:

$$f(x,y) = \begin{cases} y^2 \sin\left(\frac{x}{y}\right), & (x,y) \neq (0,0), \\ 0, & (x,y) = (0,0), \end{cases}$$

Study the continuity of f on all of \mathbb{R}^2 .

Solution. For all $(x,y) \in \mathbb{R}^2 \setminus \{(x,0)\}$, the function $f(x,y)$ is continuous function, since it is a product of two continuous functions.

Next, we study the continuity of $f(x,y)$ outside the plan $\mathbb{R}^2 \setminus \{(x,0)\}$, specifically, at the point $(x,0)$, $x \in \mathbb{R}$. To achieve this purpose, we need to show that $\lim_{(x,y) \rightarrow (x,0)} f(x,y)$ exists and is equal to $f(x,0)$, i.e.,

$$\lim_{(x,y) \rightarrow (x,0)} y^2 \sin\left(\frac{x}{y}\right) = f(x,0) = 0.$$

We have

$$0 \leq \left| y^2 \sin\left(\frac{x}{y}\right) \right| \leq y^2, \quad \text{due to the fact that } \left| \sin\left(\frac{x}{y}\right) \right| \leq 1.$$

Therefore, we have

$$0 \leq \lim_{(x,y) \rightarrow (x,0)} \left| y^2 \sin\left(\frac{x}{y}\right) \right| \leq \lim_{(x,y) \rightarrow (x,0)} y^2 \overset{0}{\rightarrow} 0,$$

which implies that $\lim_{(x,y) \rightarrow (x,0)} f(x,y) = f(x,0) = 0$, and hence f is continuous function at the point $(x,0)$. Then, we can conclude that f is continuous function on all of \mathbb{R}^2 .

Exercise 3.4. Show that

$$f(x,y) = \begin{cases} \frac{x^2 + y^2}{|x| + |y|} \sin(xy), & (x,y) \neq (0,0), \\ 0, & (x,y) = (0,0), \end{cases}$$

is continuous function on all of \mathbb{R}^2 .

Solution. The function f is continuous for all $(x, y) \in \mathbb{R}^2 \setminus \{(0, 0)\}$ since f is expressed as a quotient of two continuous functions $(x^2 + y^2) \sin(xy)$ and $|x| + |y|$ and the denominator is not vanishing.

Recalling that f is continuous at the point $(0, 0)$ if

$$\lim_{(x,y) \rightarrow (0,0)} \frac{x^2 + y^2}{|x| + |y|} \sin(xy) = f(0, 0) = 0.$$

We have

$$0 \leq \left| \frac{x^2 + y^2}{|x| + |y|} \sin(xy) \right| \leq \frac{x^2 + y^2}{|x| + |y|}, \quad \text{because } |\sin(xy)| \leq 1.$$

We can easily observe that $x^2 + y^2 \leq (|x| + |y|)^2$. Then, we can obtain

$$\begin{aligned} 0 \leq \lim_{(x,y) \rightarrow (0,0)} \left| \frac{x^2 + y^2}{|x| + |y|} \sin(xy) \right| &\leq \lim_{(x,y) \rightarrow (0,0)} (|x| + |y|) \cdot \frac{|x| + |y|}{|x| + |y|} \\ &= \lim_{(x,y) \rightarrow (0,0)} (|x| + |y|) \\ &= 0. \end{aligned}$$

Thus, $\lim_{(x,y) \rightarrow (0,0)} f(x, y) = 0 = f(0, 0)$ which implies that f is continuous function at the point $(0, 0)$. Finally, we may conclude that f is continuous on all of \mathbb{R}^2 .

Exercise 3.5. Study the continuity of:

$$f(x, y) = \begin{cases} \frac{y^3}{(x-1)^2 + y^2}, & (x, y) \neq (1, 0), \\ 0, & (x, y) = (1, 0). \end{cases}$$

Hint: Use polar coordinates.

Solution. For all $(x, y) \neq (1, 0)$, the function $f(x, y)$ is continuous function because it is a quotient of two continuous function and the denominator does not vanish.

Now, it remains to investigate the continuity of the function f at the point $(1, 0)$. By using the polar coordinates:

$$\begin{cases} x - 1 = r \cos \theta, \\ y = r \sin \theta, \end{cases}$$

we can get

$$\begin{aligned} \lim_{(x,y) \rightarrow (1,0)} \frac{y^3}{(x-1)^2 + y^2} &= \lim_{r \rightarrow 0} \frac{r^3 \sin^3 \theta}{r^2 (\cos^2 \theta + \sin^2 \theta)} \\ &= r \sin^3 \theta \\ &= 0. \end{aligned}$$

Thus, we have $\lim_{(x,y) \rightarrow (1,0)} f(x,y) = f(1,0) = 0$, and hence f is continuous function at the point $(1,0)$. In summary, we have shown that f is continuous function for all $(x,y) \in \mathbb{R}^2$.

Exercise 3.6. Consider

$$f(x,y) = \begin{cases} \frac{xy}{\sqrt{x^2+y^4}}, & (x,y) \neq (0,0), \\ 0, & (x,y) = (0,0). \end{cases}$$

Prove that $f(x,y)$ is continuous function at origin.

Solution. To study the continuity of the function $f(x,y)$ at the point $(0,0)$, we must investigate whether the limit of $f(x,y)$ exists as (x,y) approaches $(0,0)$ and whether it is equal to $f(0,0)$?

We have

$$\begin{aligned} 0 \leq \left| \frac{xy}{\sqrt{x^2+y^4}} \right| &\leq \frac{|x||y|}{\sqrt{x^2+y^4}} \\ &\leq \frac{1}{\sqrt{2}} \frac{|x||y|}{\sqrt{|x||y|}}, \end{aligned}$$

where we have used $x^2 + y^4 \geq 2|x|y^2$ to get the last step. Therefore, we have

$$0 \leq \lim_{(x,y) \rightarrow (0,0)} \left| \frac{xy}{\sqrt{x^2+y^4}} \right| \leq \frac{1}{\sqrt{2}} \lim_{(x,y) \rightarrow (0,0)} \sqrt{|x|} \rightarrow 0$$

Thus, we get $\lim_{(x,y) \rightarrow (0,0)} f(x,y) = f(0,0) = 0$. This implies that the function $f(x,y)$ is continuous at the origin.

Exercise 3.7. Consider

$$f(x,y) = \begin{cases} \frac{xy}{\sqrt{x^2+y^4}} \sin\left(\frac{x^2y}{x^2+y^2}\right), & (x,y) \neq (0,0), \\ 0, & (x,y) = (0,0). \end{cases}$$

Show that f is continuous function on all of \mathbb{R}^2 .

Solution. For all $(x,y) \neq 0$, we can observe that $f(x,y)$ is product of two continuous functions, and hence f is continuous function on $\mathbb{R}^2 \setminus \{(0,0)\}$. Indeed, the function xy is continuous on \mathbb{R}^2 and the quotient function $\frac{1}{\sqrt{x^2+y^4}}$ is continuous for all $(x,y) \neq 0$, which implies that $\frac{xy}{\sqrt{x^2+y^4}}$ is continuous function on $\mathbb{R}^2 \setminus \{(0,0)\}$. Similarly, the function $\sin\left(\frac{x^2y}{x^2+y^2}\right)$ is also continuous on $\mathbb{R}^2 \setminus \{(0,0)\}$.

Next, we pass to study the continuity of the function $f(x, y)$ at origin. Before going further, we recall that

$$\lim_{t \rightarrow 0} \frac{\sin t}{t} = 1.$$

Now, we have

$$\lim_{(x,y) \rightarrow (0,0)} \frac{xy}{\sqrt{x^2 + y^4}} \sin\left(\frac{x^2 y}{x^2 + y^2}\right) = \lim_{(x,y) \rightarrow (0,0)} \frac{xy}{\sqrt{x^2 + y^4}} \cdot \frac{x^2 y}{x^2 + y^2} \cdot \frac{\sin\left(\frac{x^2 y}{x^2 + y^2}\right)}{\left(\frac{x^2 y}{x^2 + y^2}\right)}$$

Put $t = \frac{x^2 y}{x^2 + y^2}$. Then, we can see that $t \rightarrow 0$ as $(x, y) \rightarrow 0$. Indeed, by passing to the polar coordinates, we have

$$\lim_{(x,y) \rightarrow (0,0)} \frac{x^2 y}{x^2 + y^2} = \lim_{r \rightarrow 0} \frac{r^3 \sin^2 \theta \cos \theta}{r^2 (\cos^2 \theta + \sin^2 \theta)} = 0$$

Thus, we have

$$\lim_{(x,y) \rightarrow (0,0)} \frac{xy}{\sqrt{x^2 + y^4}} \sin\left(\frac{x^2 y}{x^2 + y^2}\right) = \lim_{(x,y) \rightarrow (0,0)} \frac{xy}{\sqrt{x^2 + y^4}} \cdot \frac{x^2 y}{x^2 + y^2} \cdot \frac{\sin\left(\frac{x^2 y}{x^2 + y^2}\right)}{\left(\frac{x^2 y}{x^2 + y^2}\right)}.$$

Hence, $\lim_{(x,y) \rightarrow (0,0)} f(x, y) = f(0, 0) = 0$. Therefore, f is continuous function at the origin. Finally, we have shown that f is continuous on all of \mathbb{R}^2 .

Exercise 3.8. Consider $f(x, y)$ defined by

$$f(x, y) = \begin{cases} \frac{x(1 - \cos y)\sqrt{x^2 + y^2}}{x^2 + y^4}, & (x, y) \neq (0, 0), \\ a, & (x, y) = (0, 0), \end{cases}$$

Find the value of a so that the function f is continuous at origin.

Solution. The function $f(x, y)$ is continuous at origin if

$$\lim_{(x,y) \rightarrow (0,0)} \frac{x(1 - \cos y)\sqrt{x^2 + y^2}}{x^2 + y^4} = f(0, 0) = a.$$

Recalling that

$$\lim_{t \rightarrow 0} \frac{1 - \cos t}{t^2} = \frac{1}{2}.$$

We have

$$\begin{aligned} \lim_{(x,y) \rightarrow (0,0)} \frac{x(1 - \cos y)\sqrt{x^2 + y^2}}{x^2 + y^4} &= \lim_{(x,y) \rightarrow (0,0)} \frac{1 - \cos y}{y^2} \cdot \frac{xy^2 \sqrt{x^2 + y^2}}{x^2 + y^4} \\ &= \lim_{(x,y) \rightarrow (0,0)} \frac{1 - \cos y}{y^2} \cdot \frac{1}{2} \cdot \lim_{(x,y) \rightarrow (0,0)} \frac{xy^2 \sqrt{x^2 + y^2}}{x^2 + y^4}. \end{aligned}$$

It remains to calculate the seconde limit. By using the fact that $x^2 + y^4 \geq 2|x|y^2$, we can find

$$0 \leq \left| \frac{xy^2\sqrt{x^2 + y^2}}{x^2 + y^4} \right| \leq \frac{|x|y^2\sqrt{x^2 + y^2}}{2|x|y^2},$$

which implies thta

$$0 \leq \lim_{(x,y) \rightarrow (0,0)} \left| \frac{xy^2\sqrt{x^2 + y^2}}{x^2 + y^4} \right| \leq 0.$$

Consequently, we have

$$\lim_{(x,y) \rightarrow (0,0)} \frac{x(1 - \cos y)\sqrt{x^2 + y^2}}{x^2 + y^4} = 0,$$

and hence, $a = 0$.

Exercise 3.9. Consider

$$f(x, y) = \begin{cases} \frac{2x^2(y + 1) + y^2}{2x^2 + y^2}, & (x, y) \neq (0, 0), \\ a, & (x, y) = (0, 0). \end{cases}$$

Find the value of a so that f is continuous function at $(0, 0)$.

Solution. Noting that $f(x, y)$ is continuous function at the point $(0, 0)$ if

$$\lim_{(x,y) \rightarrow (0,0)} \frac{2x^2(y + 1) + y^2}{2x^2 + y^2} = f(0, 0) = a.$$

We have

$$\lim_{(x,y) \rightarrow (0,0)} \frac{2x^2(y + 1) + y^2}{2x^2 + y^2} = \lim_{(x,y) \rightarrow (0,0)} \frac{2x^2y}{2x^2 + y^2} + 1.$$

Observe that

$$0 \leq \left| \frac{2x^2y}{2x^2 + y^2} \right| \leq \frac{2x^2|y|}{2x^2 + y^2} \leq \frac{2x^2|y|}{2x^2}$$

Thus, we have

$$0 \leq \lim_{(x,y) \rightarrow (0,0)} \left| \frac{2x^2y}{2x^2 + y^2} \right| \leq 0.$$

Hence, we can get

$$\lim_{(x,y) \rightarrow (0,0)} \frac{2x^2(y + 1) + y^2}{2x^2 + y^2} = \lim_{(x,y) \rightarrow (0,0)} \frac{2x^2y}{2x^2 + y^2} + 1 = 1.$$

Therefore $a = 1$.

Exercise 3.10. Let $f(x, y)$ be defined by

$$f(x, y) = \frac{xy}{x^2 + y^2}.$$

Determine if f can be extended to a continuous function at origin.

Solution. To prove that the function $f(x, y)$ can be continuously extended at $(0, 0)$, it is necessary to demonstrate that $\lim_{(x,y) \rightarrow (0,0)} f(x, y)$ exists.

By using polar coordinates, we can get

$$\begin{aligned} \lim_{(x,y) \rightarrow (0,0)} \frac{xy}{x^2 + y^2} &= \lim_{r \rightarrow 0} \frac{r^2 \cos \theta \sin \theta}{r^2 (\cos^2 \theta + \sin^2 \theta)} \\ &= \cos \theta \sin \theta. \end{aligned}$$

Therefore, we can see that the limit has infinite number of values depending on the choice of θ , which implies the limit does not exist. Hence, the function $f(x, y)$ can't be extended by continuity at the point $(0, 0)$.

Exercise 3.11. Consider

$$f(x, y) = \frac{y}{x^2} e^{-\frac{|y|}{x^2}}.$$

Determine if f can be extended by continuity on all of \mathbb{R}^2 .

Solution. Note that the functions $\frac{y}{x^2}$ and $\frac{|y|}{x^2}$ are defined if $x \neq 0$ and for any $y \in \mathbb{R}$. Thus, the function $f(x, y)$ is defined on $D_f = \mathbb{R}^2 \setminus \{(0, y), y \in \mathbb{R}\} = \mathbb{R}^* \times \mathbb{R}$. Therefore, the function f is continuous on D_f .

Now, it remains to study the existence of the limit of the function $f(x, y)$ outside the domain of definition D_f , specifically at the point $(0, y)$, $y \in \mathbb{R}$. To this end, we will consider the different cases:

- Case $y \neq 0$. In this case, we have

$$\begin{aligned} \lim_{(x,y) \rightarrow (0,y)} \frac{y}{x^2} e^{-\frac{|y|}{x^2}} &= \lim_{(x,y) \rightarrow (0,y)} \frac{|y|}{x^2} e^{-\frac{|y|}{x^2}} \\ &= \lim_{t \rightarrow +\infty} t e^{-t} \\ &= 0. \end{aligned}$$

Thus, $\lim_{(x,y) \rightarrow (0,y)} f(x, y)$ exists and tends to zero, and hence $f(x, y)$ can be extended by continuity at the point $(0, y)$, $y \in \mathbb{R}$.

- Case $y = 0$. In this case, we have

$$\lim_{(x,y) \rightarrow (0,0)} f(x, y) = \lim_{(x,y) \rightarrow (0,0)} \frac{y}{x^2} e^{-\frac{|y|}{x^2}}.$$

Note that the parabolic path $y = x^2$, gives

$$\lim_{\substack{x \rightarrow 0 \\ y = x^2}} \frac{y}{x^2} e^{-\frac{|y|}{x^2}} = \lim_{x \rightarrow 0} \frac{x^2}{x^2} e^{-\frac{x^2}{x^2}} = e^{-1}.$$

On the other hand, along the cubic path $y = x^3$, we obtain

$$\begin{aligned} \lim_{\substack{x \rightarrow 0 \\ y = x^3}} \frac{y}{x^3} e^{-\frac{|y|}{x^2}} &= \lim_{x \rightarrow 0} \frac{x^3}{x^2} e^{-\frac{|x|^3}{x^2}} \\ &= \lim_{x \rightarrow 0} x e^{-|x|} \\ &= 0. \end{aligned}$$

Therefore, the two limits do not coincide, which implies that $\lim_{(x,y) \rightarrow (0,0)} f(x,y)$ does not exist, and hence, f can't be extended at the origin. Consequently, we have proved that f can be extended by continuity on $\mathbb{R}^2 \setminus \{(0,0)\}$, but not on all of \mathbb{R}^2 .

Exercise 3.12. Let $f : \mathbb{R}^2 \rightarrow \mathbb{R}$ be defined by

$$f(x,y) = \frac{e^{xy^2} - 1}{x^2 + y^2}.$$

Determine if the function $f(x,y)$ can be extended by continuity at the origin.

Solution. To answer this question, we need to study the existence of the limit of f at the point $(0,0)$, i.e.,

$$\lim_{(x,y) \rightarrow (0,0)} \frac{e^{xy^2} - 1}{x^2 + y^2}.$$

Recalling that

$$\lim_{t \rightarrow 0} \frac{e^t - 1}{t} = 1.$$

Then, we have

$$\begin{aligned} \lim_{(x,y) \rightarrow (0,0)} \frac{e^{xy^2} - 1}{x^2 + y^2} &= \lim_{(x,y) \rightarrow (0,0)} \frac{e^{xy^2} - 1}{xy^2} \cdot \frac{xy^2}{x^2 + y^2} \\ &= \lim_{(x,y) \rightarrow (0,0)} \frac{e^{xy^2} - 1}{xy^2} \cdot \lim_{(x,y) \rightarrow (0,0)} \frac{xy^2}{x^2 + y^2}. \end{aligned}$$

Now, we will evaluate the following limit

$$\lim_{(x,y) \rightarrow (0,0)} \frac{xy^2}{x^2 + y^2}.$$

We have

$$\begin{aligned} 0 &\leq \left| \frac{xy^2}{x^2 + y^2} \right| \leq |y| \frac{|x||y|}{x^2 + y^2} \\ &\leq |y| \frac{\sqrt{x^2 + y^2} \sqrt{x^2 + y^2}}{x^2 + y^2}. \end{aligned}$$

Therefore, it results

$$0 \leq \lim_{(x,y) \rightarrow (0,0)} \left| \frac{xy^2}{x^2 + y^2} \right| \leq \lim_{(x,y) \rightarrow (0,0)} |y| \xrightarrow{0} 0$$

Consequently, $\lim_{(x,y) \rightarrow (0,0)} f(x, y) = 0$, which means that f can be extended by continuity at the origin.

Exercise 3.13. Consider the function

$$f(x, y) = (2x - y) \sin \left(\frac{x}{x^2 - y^2} \right).$$

Could $f(x, y)$ be extended by continuity on all of \mathbb{R}^2 ?

Solution. The function $f(x, y)$ is defined if $x^2 - y^2 \neq 0$. Since $x^2 - y^2 = (x - y)(x + y) = 0$ is the union of the lines $y = x$ or $y = -x$, the domain of definition of f is given by

$$D_f = \mathbb{R}^2 \setminus \{(x, y) \in \mathbb{R}^2 \text{ such that } y = x \text{ or } y = -x\}.$$

The function f is continuous function on D_f , since it is product of two continuous functions. Now, it remains to study the existence of the limit of the function f outside the domain of definition D_f , specifically, at the points of the type (x, x) or $(x, -x)$. To achieve this purpose, we consider two different cases:

• Case $x = 0$. Since $\left| \sin \left(\frac{x}{x^2 - y^2} \right) \right| \leq 1$, we have

$$0 \leq |(2x - y)| \left| \sin \left(\frac{x}{x^2 - y^2} \right) \right| \leq |2x - y|.$$

Therefore, we have

$$0 \leq \lim_{(x,y) \rightarrow (0,0)} f(x, y) \leq \lim_{(x,y) \rightarrow (0,0)} |2x - y| \xrightarrow{0} 0 \tag{3.3}$$

Thus, $\lim_{(x,y) \rightarrow (0,0)} f(x, y) = 0$, and hence the function f can be extended by continuity at the origin.

• Case $x \neq 0$ and $(x, y) = (x, x)$. In this case, we have

$$\lim_{(x,y) \rightarrow (x,x)} (2x - y) = 0,$$

and $\lim_{(x,y) \rightarrow (x,x)} \frac{x}{x^2 - y^2}$ does not exist, which implies that $f(x, y)$ does not admit a limit at the point (x, x) , with $x \neq 0$.

• Case $x \neq 0$ and $(x, y) = (x, -x)$. In the same manner as before, we can show that f does not admit a limit this point. As conclusion, we can observe that f can be extended by continuity on $D_f \cup \{(0, 0)\}$; but not on all of \mathbb{R}^2 .

Exercise 3.14. Let $\alpha > 0$ and $f : \mathbb{R}^2 \rightarrow \mathbb{R}$ be defined by

$$f(x, y) = \begin{cases} \frac{xy}{(x^2 + y^2)^\alpha}, & (x, y) \neq (0, 0), \\ 0, & (x, y) = (0, 0). \end{cases}$$

For what value of α will f be continuous function at origin ?

Solution. f is continuous function at $(0, 0)$ if

$$\lim_{(x,y) \rightarrow (0,0)} \frac{xy}{(x^2 + y^2)^\alpha} = f(0, 0) = 0.$$

From $|x| \leq \sqrt{x^2 + y^2}$ and $|y| \leq \sqrt{x^2 + y^2}$, it yields

$$0 \leq \left| \frac{xy}{(x^2 + y^2)^\alpha} \right| \leq \frac{x^2 + y^2}{(x^2 + y^2)^\alpha} = (x^2 + y^2)^{1-\alpha}.$$

Therefore, we have

$$0 \leq \lim_{(x,y) \rightarrow (0,0)} \left| \frac{xy}{(x^2 + y^2)^\alpha} \right| \leq \lim_{(x,y) \rightarrow (0,0)} (x^2 + y^2)^{1-\alpha}.$$

Now, if $0 < \alpha < 1$, then $(x^2 + y^2)^{1-\alpha}$ tends to zero as (x, y) approaches $(0, 0)$, and hence we can see that f is continuous at the origin if $\alpha > 1$.

Exercise 3.15. Let $\alpha \geq 0$ and let $f : \mathbb{R}^2 \rightarrow \mathbb{R}$ be given as

$$f(x, y) = \begin{cases} \frac{x^\alpha y}{x^2 + y^2}, & (x, y) \neq (0, 0), \\ 0, & (x, y) = (0, 0), \end{cases}$$

Determine the value of α that would make f continuous function at origin.

Solution. Recalling that f is continuous at the point $(0, 0)$ if

$$\lim_{(x,y) \rightarrow (0,0)} \frac{x^\alpha y}{x^2 + y^2} = f(0, 0) = 0.$$

If $\alpha = 0$, then along the path $y = 0$, we have

$$\lim_{\substack{x \rightarrow 0 \\ y=0}} f(x, y) = 0.$$

On the other hand, the diagonal path $y = x$ gives

$$\lim_{\substack{x \rightarrow 0 \\ y=x}} f(x, y) = \frac{1}{2}.$$

Therefore, the two-path test tells us that $f(x, y)$ cannot have a limit at the origin, and hence f is not continuous at this point.

Let $\alpha > 0$. By using polar coordinates, we can obtain

$$\begin{aligned}\lim_{(x,y) \rightarrow (0,0)} f(x, y) &= \lim_{\substack{r \rightarrow 0 \\ \forall \theta}} \frac{r^\alpha \cos^\alpha \theta \cdot r^2 \sin^2 \theta}{r^2 (\cos^2 \theta + \sin^2 \theta)} \\ &= \lim_{\substack{r \rightarrow 0 \\ \forall \theta}} r^\alpha \cos^\alpha \theta \sin^2 \theta.\end{aligned}$$

Since $|\cos^\alpha \theta \sin^2 \theta| \leq 1$, we have $0 \leq |r^\alpha \cos^\alpha \theta \sin^2 \theta| \leq r^\alpha$. Thus, it yields

$$0 \leq \lim_{\substack{r \rightarrow 0 \\ \forall \theta}} |r^\alpha \cos^\alpha \theta \sin^2 \theta| \leq \lim_{r \rightarrow 0} r^\alpha$$

If $\alpha > 0$, then $\lim_{r \rightarrow 0} r^\alpha = 0$, and hence $\lim_{(x,y) \rightarrow (0,0)} f(x, y) = f(0, 0) = 0$, which implies that f is continuous at the point $(0, 0)$ if $\alpha > 0$.

Chapter 4

Partial derivatives

1 Partial derivatives of $f : \mathbb{R}^n \rightarrow \mathbb{R}$

Definition 1.1 (Partial derivatives at a point). *Let $f : D \subseteq \mathbb{R}^n \rightarrow \mathbb{R}$ be a function of several variables $x = (x_1, x_2, \dots, x_n)$. If the following limit exist*

$$\frac{\partial f}{\partial x_i}(x) = \lim_{h \rightarrow 0} \frac{f(x + he_i) - f(x)}{h}, \quad \text{where } e_i \text{ is the } i\text{-th unit vector,}$$

then it is called the partial derivative of f with respect to x_i at the point x .

Example 1.2. *By employing Definition 1.1, evaluate the partial derivatives of*

$$f(x, y) = 2x^3 + 6xy - y^2.$$

The partial derivative of f with respect to x , is given by

$$\begin{aligned} \frac{\partial f}{\partial x}(x, y) &= \lim_{h \rightarrow 0} \frac{f(x + h, y) - f(x, y)}{h} \\ &= \lim_{h \rightarrow 0} \frac{2(x + h)^3 + 6(x + h)y - y^2 - 2x^3 - 6xy + y^2}{h} \\ &= \lim_{h \rightarrow 0} \frac{2x^2h + 6xh^2 + 2h^3 + 6yh}{h} \\ &= \lim_{h \rightarrow 0} (2x^2 + 6xh + 2h^2 + 6y) \\ &= 2x^2 + 6y. \end{aligned}$$

Analogously, the partial derivative of f with respect to y , is given as

$$\begin{aligned} \frac{\partial f}{\partial x}(x, y) &= \lim_{h \rightarrow 0} \frac{f(x, y+h) - f(x, y)}{h} \\ &= \lim_{h \rightarrow 0} \frac{2x^3 + 6x(y+h) - (y+h)^2 - 2x^3 - 6xy + y^2}{h} \\ &= \lim_{h \rightarrow 0} \frac{6xh - 2yh + h^2}{h} \\ &= \lim_{h \rightarrow 0} (6x - 2y + h) \\ &= 6x - 2y. \end{aligned}$$

- Although the results obtained using Definition 1.1 are correct. However, finding the partial derivative utilizing this approach is not very practical. Instead, for practical calculations, we can calculate the partial derivatives in the same way as ordinary derivatives, assuming that all other variables except the one we are calculating with respect to are treated as constants.

Example 1.3. Let $f(x, y)$ defined by

$$f(x, y) = x^2 + y^2 + \sin(x^3 - 2y), \quad \text{for all } (x, y) \in \mathbb{R}^2.$$

Find the partial derivatives of f on all of \mathbb{R}^2 .

To find the partial derivative of f with respect to x , we will fix the second variable y and then evaluate the derivative of the f with respect to x to find:

$$\frac{\partial f}{\partial x}(x, y) = 2x + 3x^2 \cos(x - 2y),$$

and in the same manner the partial derivative with respect to y is given as

$$\frac{\partial f}{\partial y}(x, y) = 2y - 2 \cos(x^3 - 2y).$$

Definition 1.4. Let $f : D \subseteq \mathbb{R}^n \rightarrow \mathbb{R}$ where D is open of D . If all partial derivatives $\frac{\partial f}{\partial x_i}$, $i = 1, 2, \dots, n$ exist for every $x \in D$ and are continuous on D , then we say f is continuously differentiable function on D and hence, we write $f \in C^1(D)$ and say f is of class C^1 on D .

Example 1.5. Consider

$$f(x, y) = \begin{cases} x^2 y^2 \ln(x^2 + y^2), & (x, y) \neq (0, 0), \\ 0, & (x, y) = (0, 0), \end{cases}$$

Prove that f is of class C^1 on \mathbb{R}^2 .

To show that f is of class \mathcal{C}^1 , it suffice to prove that its partial derivatives exit and continuous on all of \mathbb{R}^2 . First of all, notice that for all $(x, y) \in \mathbb{R}^2 \setminus \{(0, 0)\}$, the function $f \in \mathcal{C}^1$ since f is expressed as the product of two functions of class \mathcal{C}^1 on $\mathbb{R}^2 \setminus \{(0, 0)\}$. Indeed, for all $(x, y) \in \mathbb{R}^2 \setminus \{(0, 0)\}$, we have

$$\frac{\partial f}{\partial x}(x, y) = 2xy^2 \ln(x^2 + y^2) + \frac{2x^3y^2}{x^2 + y^2},$$

and

$$\frac{\partial f}{\partial y}(x, y) = 2x^2y \ln(x^2 + y^2) + \frac{2x^2y^3}{x^2 + y^2},$$

Hence, $\frac{\partial f}{\partial x}$ and $\frac{\partial f}{\partial y}$ are continuous function on $\mathbb{R}^2 \setminus \{(0, 0)\}$. Moreover, at the point $(0, 0)$, we have

$$\frac{\partial f}{\partial x}(0, 0) = \lim_{h \rightarrow 0} \frac{f(h, 0) - \overset{0}{f(0, 0)}}{h} = \lim_{h \rightarrow 0} \frac{h^2 \cdot 0^2 \cdot \ln(h^2 + 0^2)}{h} = \lim_{h \rightarrow 0} \frac{0}{h} = 0,$$

and similarly, we have

$$\frac{\partial f}{\partial y}(0, 0) = \lim_{h \rightarrow 0} \frac{f(0, h) - \overset{0}{f(0, 0)}}{h} = \lim_{h \rightarrow 0} \frac{0^2 \cdot h^2 \cdot \ln(0^2 + h^2)}{h} = \lim_{h \rightarrow 0} \frac{0}{h} = 0.$$

Therefore, it follows

$$\frac{\partial f}{\partial x}(x, y) = \begin{cases} 2xy^2 \ln(x^2 + y^2) + \frac{2x^3y^2}{x^2 + y^2}, & (x, y) \neq (0, 0), \\ 0, & (x, y) = (0, 0), \end{cases}$$

and

$$\frac{\partial f}{\partial y}(x, y) = \begin{cases} 2x^2y \ln(x^2 + y^2) + \frac{2x^2y^3}{x^2 + y^2}, & (x, y) \neq (0, 0), \\ 0, & (x, y) = (0, 0). \end{cases}$$

Now, we need to show that $\frac{\partial f}{\partial x}$ and $\frac{\partial f}{\partial y}$ are continuous at the point $(0, 0)$. To this end, we will evaluate the limit of both $\frac{\partial f}{\partial x}(x, y)$ and $\frac{\partial f}{\partial y}(x, y)$ when (x, y) approaches $(0, 0)$. So, we have

$$\begin{aligned} \lim_{(x,y) \rightarrow (0,0)} \frac{\partial f}{\partial x}(x, y) &= \lim_{(x,y) \rightarrow (0,0)} \left[2xy^2 \ln(x^2 + y^2) + \frac{2x^3y^2}{x^2 + y^2} \right] \\ &= \lim_{(x,y) \rightarrow (0,0)} 2xy^2 \ln(x^2 + y^2) + \lim_{(x,y) \rightarrow (0,0)} \frac{2x^3y^2}{x^2 + y^2} \\ &= \lim_{(x,y) \rightarrow (0,0)} \frac{2xy^2}{x^2 + y^2} \cdot \lim_{(x,y) \rightarrow (0,0)} \overset{0}{(x^2 + y^2) \ln(x^2 + y^2)} + \lim_{(x,y) \rightarrow (0,0)} \frac{2x^3y^2}{x^2 + y^2} \\ &= 0 = \frac{\partial f}{\partial x}(0, 0), \end{aligned}$$

since $\lim_{(x,y) \rightarrow (0,0)} \frac{2xy^2}{x^2 + y^2} = 0$ and $\lim_{(x,y) \rightarrow (0,0)} \frac{2x^3y^2}{x^2 + y^2} = 0$ by passing to the polar coordinates. Analogously, we obtain

$$\lim_{(x,y) \rightarrow (0,0)} \frac{\partial f}{\partial y}(x, y) = \lim_{(x,y) \rightarrow (0,0)} 2x^2y \ln(x^2 + y^2) + \frac{2x^2y^3}{x^2 + y^2} = 0 = \frac{\partial f}{\partial y}(0, 0).$$

Thus, the partial derivatives $\frac{\partial f}{\partial x}$ and $\frac{\partial f}{\partial y}$ are continuous at the point $(0, 0)$. In conclusion, we have shown that f is of class \mathcal{C}^1 on all of \mathbb{R}^2 .

Directional derivative:

The partial derivative is a special case of the directional derivative which we will now define.

Definition 1.6 (Directional derivative). *Let \mathcal{D} be an open set of \mathbb{R}^n . Suppose that $f : \mathcal{D} \rightarrow \mathbb{R}$ and let $v \in \mathbb{R}^n \setminus \{0\}$. If*

$$\partial_v f(x) = \lim_{t \rightarrow 0} \frac{f(x + tv) - f(x)}{t}$$

exists, we call it the directional derivative of f in direction v at the point $x \in \mathcal{D}$.

Remark 1.7. *Observe that if v is one of the unit coordinate vectors, then we recover the notion of partial derivative.*

Example 1.8. *Evaluate the directional derivative of $f(x, y) = x^2 + xy$ at $(1, 2)$ in the direction of $v = \left(\frac{1}{\sqrt{2}}, \frac{1}{\sqrt{2}}\right)$.*

Let $v = \left(\frac{1}{\sqrt{2}}, \frac{1}{\sqrt{2}}\right)$. Then, by applying the Definition 1.6, we find

$$\begin{aligned} \partial_f(1, 2) &= \lim_{t \rightarrow 0} \frac{f\left(1 + \frac{t}{\sqrt{2}}, 2 + \frac{t}{\sqrt{2}}\right) - f(1, 2)}{t} \\ &= \lim_{t \rightarrow 0} \frac{\left(1 + \frac{t}{\sqrt{2}}\right)^2 + \left(1 + \frac{t}{\sqrt{2}}\right)\left(2 + \frac{t}{\sqrt{2}}\right) - (1^2 + 1 \cdot 2)}{t} \\ &= \lim_{t \rightarrow 0} \frac{\frac{5t}{\sqrt{2}} + t^2}{t} \\ &= \lim_{t \rightarrow 0} \left(\frac{5}{\sqrt{2}} + t\right) = \frac{5}{\sqrt{2}}. \end{aligned}$$

Hence, the rate of change of $f(x, y) = x^2 + xy$ at the point $(1, 2)$ in the direction v is $\frac{5}{\sqrt{2}}$.

Example 1.9. *Evaluate the directional derivative of $f(x) = \|x\|_2$ at the point $x \in \mathbb{R}^n \setminus \{0\}$ in the direction v .*

Let $v \in \mathbb{R}^n \setminus \{0\}$ and $\|x\|_2 = \left(\sum_{i=1}^n x_i^2\right)^{\frac{1}{2}}$. Then, we have

$$\begin{aligned}
 \partial_v f(x) &= \lim_{t \rightarrow 0} \frac{f(x + tv) - f(x)}{t} \\
 &= \lim_{t \rightarrow 0} \frac{\|x + tv\|_2 - \|x\|_2}{t} \\
 &= \lim_{t \rightarrow 0} \frac{\left(\sum_{i=1}^n (x_i + tv_i)^2\right)^{\frac{1}{2}} - \left(\sum_{i=1}^n x_i^2\right)^{\frac{1}{2}}}{t} \\
 &= \lim_{t \rightarrow 0} \frac{\sum_{i=1}^n (x_i + tv_i)^2 - \sum_{i=1}^n x_i^2}{t \left[\left(\sum_{i=1}^n (x_i + tv_i)^2\right)^{\frac{1}{2}} + \left(\sum_{i=1}^n x_i^2\right)^{\frac{1}{2}} \right]} \\
 &= \lim_{t \rightarrow 0} \frac{\sum_{i=1}^n x_i^2 + 2t \sum_{i=1}^n x_i v_i + t^2 \sum_{i=1}^n v_i^2 - \sum_{i=1}^n x_i^2}{t \left[\left(\sum_{i=1}^n (x_i + tv_i)^2\right)^{\frac{1}{2}} + \left(\sum_{i=1}^n x_i^2\right)^{\frac{1}{2}} \right]} \\
 &= \frac{\sum_{i=1}^n x_i v_i}{\left(\sum_{i=1}^n x_i^2\right)^{\frac{1}{2}}} = \sum_{i=1}^n \frac{x_i}{\|x\|_2} v_i.
 \end{aligned}$$

If $v = e_i$ we recover the formula $\frac{\partial \|x\|_2}{\partial x_i} = \frac{x_i}{\|x\|_2}$.

Definition 1.10. Let \mathcal{D} be an open set of \mathbb{R}^n . Let $f : \mathcal{D} \rightarrow \mathbb{R}$ and assume that all its partial derivatives exist at $x \in \mathcal{D}$. We call the vector field $\nabla f(x) \in \mathbb{R}^n$ defined by

$$\nabla f(x) = \begin{pmatrix} \frac{\partial f}{\partial x_1}(x) \\ \frac{\partial f}{\partial x_2}(x) \\ \vdots \\ \frac{\partial f}{\partial x_n}(x) \end{pmatrix}$$

the gradient of f at x .

Example 1.11. Given $f(x, y) = e^{3(x-y^2)} \sin(x^2 + y^2)$. Determine $\nabla f(x, y)$.

We have f defined on all of \mathbb{R}^2 . Then, for all $(x, y) \in \mathbb{R}^2$, we have

$$\nabla f(x, y) = \begin{pmatrix} \frac{\partial f}{\partial x}(x, y) \\ \frac{\partial f}{\partial y}(x, y) \end{pmatrix} = \begin{pmatrix} e^{3(x-y^2)} (3 \sin(x^2 + y^2) + 2x \cos(x^2 + y^2)) \\ 2ye^{3(x-y^2)} (-3 \sin(x^2 + y^2) + \cos(x^2 + y^2)) \end{pmatrix}.$$

Example 1.12. Given

$$f(x, y) = \begin{cases} \frac{x^2(y-1)}{\sqrt{x^2 + (y-1)^2}}, & (x, y) \neq (0, 1), \\ 0, & (x, y) = (0, 1). \end{cases}$$

Determine $\nabla f(x, y)$.

For $(x, y) \neq (0, 1)$, we have

$$\nabla f(x, y) = \begin{pmatrix} \frac{\partial f}{\partial x}(x, y) \\ \frac{\partial f}{\partial y}(x, y) \end{pmatrix} = \begin{pmatrix} \frac{x(y-1)[x^2 + 2(y-1)^2]}{(x^2 + (y-1)^2)^{\frac{3}{2}}} \\ \frac{x^4}{(x^2 + (y-1)^2)^{\frac{3}{2}}} \end{pmatrix}.$$

For $(x, y) = (0, 1)$, we have

$$\nabla f(0, 1) = \begin{pmatrix} \frac{\partial f}{\partial x}(0, 1) \\ \frac{\partial f}{\partial y}(0, 1) \end{pmatrix}.$$

So, we have

$$\frac{\partial f}{\partial x}(0, 1) = \lim_{h \rightarrow 0} \frac{f(0+h, 1) - \overset{0}{\cancel{f(0, 1)}}}{h} = \lim_{h \rightarrow 0} \frac{\overset{0}{\cancel{\frac{h^2 \cdot 0}{\sqrt{h^2+0}}}}}{h} = 0,$$

and

$$\frac{\partial f}{\partial y}(0, 1) = \lim_{h \rightarrow 0} \frac{f(0, 1+h) - \overset{0}{\cancel{f(0, 1)}}}{h} = \lim_{h \rightarrow 0} \frac{\overset{0}{\cancel{\frac{0 \cdot h^2}{\sqrt{0^2+h^2}}}}}{h} = 0.$$

Hence, we have

$$\nabla f(0, 1) = \begin{pmatrix} 0 \\ 0 \end{pmatrix}.$$

Definition 1.13 (Partial derivatives for vector-valued functions). Let $f : D \subseteq \mathbb{R}^n \rightarrow \mathbb{R}^m$.

We say that the i -th partial derivative of f at $x \in D$ exists, if it exists for all components f_1, f_2, \dots, f_m . In that case we write

$$\frac{\partial f}{\partial x_i} = \begin{pmatrix} \frac{\partial f_1}{\partial x_i} \\ \frac{\partial f_2}{\partial x_i} \\ \vdots \\ \frac{\partial f_m}{\partial x_i} \end{pmatrix}$$

Definition 1.14 (Jacobian matrix). Suppose that $f : D \subseteq \mathbb{R}^n \rightarrow \mathbb{R}^m$ and that all partial derivatives exist at $x \in D$. Then the $(m \times n)$ -matrix

$$\mathbf{J}(f)(x) = \begin{pmatrix} \frac{\partial f_1}{\partial x_1}(x) & \frac{\partial f_1}{\partial x_2}(x) & \cdots & \frac{\partial f_1}{\partial x_n}(x) \\ \frac{\partial f_2}{\partial x_1}(x) & \frac{\partial f_2}{\partial x_2}(x) & \cdots & \frac{\partial f_2}{\partial x_n}(x) \\ \vdots & \vdots & \ddots & \vdots \\ \frac{\partial f_m}{\partial x_1}(x) & \frac{\partial f_m}{\partial x_2}(x) & \cdots & \frac{\partial f_m}{\partial x_n}(x) \end{pmatrix}$$

is called the Jacobian matrix of the function f at the point x .

If $n = m$, we call $\det\{\mathbf{J}\}(f)(x)$ the Jacobian determinant of f at x .

Example 1.15. Consider $f : \mathbb{R}^3 \rightarrow \mathbb{R}^3$ given by

$$f(x, y, z) = (4x^2 + y, z \sin(2x - y), 2yz^2 - x).$$

Find the Jacobian matrix of f .

By Definition 1.14, the Jacobian matrix of f is 3×3 -matrix and is given as

$$\mathbf{J}(f)(x, y, z) = \begin{pmatrix} \frac{\partial f_1}{\partial x} & \frac{\partial f_1}{\partial y} & \frac{\partial f_1}{\partial z} \\ \frac{\partial f_2}{\partial x} & \frac{\partial f_2}{\partial y} & \frac{\partial f_2}{\partial z} \\ \frac{\partial f_3}{\partial x} & \frac{\partial f_3}{\partial y} & \frac{\partial f_3}{\partial z} \end{pmatrix} = \begin{pmatrix} 8x & 1 & 0 \\ 2z \cos(x - y) & -z \cos(x - y) & \sin(2x - y) \\ -1 & 2z^2 & 4yz \end{pmatrix}.$$

2 Higher order derivative

The partial derivatives of a function $f : D \subseteq \mathbb{R}^n \rightarrow \mathbb{R}$ with respect to $x_i, i = 1, \dots, n$, are functions of $x = (x_1, x_2, \dots, x_n) \in D$. Therefore, we can extend the idea of partial derivatives of second order, whenever they exist, by using the process of partial differentiation iteratively for $i, j = 1, 2, \dots, n$ as follows:

$$\frac{\partial^2 f}{\partial x_j \partial x_i}(x) = \frac{\partial}{\partial x_j} \left(\frac{\partial f}{\partial x_i} \right) (x).$$

Moreover, by repeating the process of partial differentiation we could obtain third (and higher) order partial derivatives, if they exist. For example,

$$\frac{\partial^3 f}{\partial x_k \partial x_j \partial x_i^2}(x) = \frac{\partial^2}{\partial x_k \partial x_j} \left(\frac{\partial f}{\partial x_i} \right) (x).$$

for $i, j, k = 1, 2, \dots, n$.

In the case when $n = 2$, for a function $f(x, y) : D \subseteq \mathbb{R}^2 \longrightarrow \mathbb{R}$, if the following limits exist

$$\begin{aligned}\frac{\partial^2 f}{\partial x^2}(x, y) &= \frac{\partial}{\partial x} \left(\frac{\partial f}{\partial x} \right) (x, y) = \lim_{h \rightarrow 0} \frac{\frac{\partial f}{\partial x}(x+h, y) - \frac{\partial f}{\partial x}(x, y)}{h}, \\ \frac{\partial^2 f}{\partial y^2}(x, y) &= \frac{\partial}{\partial y} \left(\frac{\partial f}{\partial y} \right) (x, y) = \lim_{h \rightarrow 0} \frac{\frac{\partial f}{\partial y}(x, y+h) - \frac{\partial f}{\partial y}(x, y)}{h}, \\ \frac{\partial^2 f}{\partial x \partial y}(x, y) &= \frac{\partial}{\partial x} \left(\frac{\partial f}{\partial y} \right) (x, y) = \lim_{h \rightarrow 0} \frac{\frac{\partial f}{\partial y}(x+h, y) - \frac{\partial f}{\partial y}(x, y)}{h}, \\ \frac{\partial^2 f}{\partial y \partial x}(x, y) &= \frac{\partial}{\partial y} \left(\frac{\partial f}{\partial x} \right) (x, y) = \lim_{h \rightarrow 0} \frac{\frac{\partial f}{\partial x}(x, y+h) - \frac{\partial f}{\partial x}(x, y)}{h}.\end{aligned}$$

then, they are called the second order partial derivatives of $f(x, y)$. The last two are referred to as the mixed second order partial derivatives of the function $f(x, y)$.

Example 2.1. *Given*

$$f(x, y) = 3x^2 + 2xy + y^3 \sin x.$$

Evaluate the second order partial derivatives of f .

The partial derivative of f with respect to x is given as

$$\frac{\partial f}{\partial x}(x, y) = 6x + 2y + y^3 \cos x,$$

and the second order partial derivative of f with respect to x can be obtained as

$$\begin{aligned}\frac{\partial^2 f}{\partial x^2}(x, y) &= \frac{\partial}{\partial x} \left(\frac{\partial f}{\partial x} \right) (x, y) \\ &= \frac{\partial}{\partial x} (6x + 2y + y^3 \cos x) \\ &= 6 - y^2 \sin x.\end{aligned}$$

In the same manner, the partial derivative of f with respect to y reads

$$\frac{\partial f}{\partial y}(x, y) = 2x + 3y^2 \sin x,$$

and the second order partial derivative of f with respect to y is given as

$$\begin{aligned}\frac{\partial^2 f}{\partial y^2}(x, y) &= \frac{\partial}{\partial y} \left(\frac{\partial f}{\partial y} \right) (x, y) \\ &= \frac{\partial}{\partial y} (2x + 3y^2 \sin x) \\ &= 6y \sin x.\end{aligned}$$

Moreover, the mixed second order partial derivatives of f are given as

$$\begin{aligned}\frac{\partial^2 f}{\partial y \partial x}(x, y) &= \frac{\partial}{\partial y} \left(\frac{\partial f}{\partial x} \right) (x, y) \\ &= \frac{\partial}{\partial y} (6x + 2y + y^3 \cos x) \\ &= 2 + 3y^2 \cos x,\end{aligned}$$

and

$$\begin{aligned}\frac{\partial^2 f}{\partial x \partial y}(x, y) &= \frac{\partial}{\partial x} \left(\frac{\partial f}{\partial y} \right) (x, y) \\ &= \frac{\partial}{\partial x} (2x + 3y^2 \sin x) \\ &= 2 + 3y^2 \cos x.\end{aligned}$$

Notice that, in this case, we have $\frac{\partial^2 f}{\partial y \partial x}(x, y) = \frac{\partial^2 f}{\partial x \partial y}(x, y)$.

Definition 2.2. Let $f : D \subseteq \mathbb{R}^n \rightarrow \mathbb{R}$. If the second order partial derivatives $\frac{\partial^2 f}{\partial x_j \partial x_i}$, $i, j = 1, 2, \dots, n$, all exist and are continuous on D , then we say that f is of class \mathcal{C}^2 on D and we write $f \in \mathcal{C}^1(D)$.

When, for each positive integer k , all the k -th order partial derivatives of f exist and are continuous on D , then we say f is of class \mathcal{C}^k , and we write $f \in \mathcal{C}^k(D)$.

Moreover, a function f is of class $\mathcal{C}^\infty(D)$, if f has all its partial derivatives of all orders, that is, $f \in \mathcal{C}^\infty(D)$ if $f \in \mathcal{C}^k(D)$ for all $k = 1, 2, \dots$.

Theorem 2.3 (Schwarz Theorem). Let $f : D \subseteq \mathbb{R}^n \rightarrow \mathbb{R}$ be of class \mathcal{C}^2 on D . Then the mixed partial derivatives are interchangeable, i.e.,

$$\frac{\partial^2 f}{\partial x_i \partial x_j}(x) = \frac{\partial^2 f}{\partial x_j \partial x_i},$$

for all $x \in D$.

Example 2.4 (Partial Derivatives are not always Interchangeable). Consider $f : \mathbb{R}^2 \rightarrow \mathbb{R}$ defined by

$$f(x, y) = \begin{cases} xy \frac{x^2 - y^2}{x^2 + y^2}, & (x, y) \neq (0, 0), \\ 0, & (x, y) = (0, 0). \end{cases}$$

Then, we can show that $f \in \mathcal{C}^1(\mathbb{R}^2)$, but $\frac{\partial^2 f}{\partial x \partial y}(0, 0) \neq \frac{\partial^2 f}{\partial y \partial x}(0, 0)$.

Indeed, we have

$$\frac{\partial f}{\partial x}(x, y) = \begin{cases} y \frac{x^4 + 4x^2 y^2 - y^4}{(x^2 + y^2)^2}, & (x, y) \neq (0, 0), \\ 0, & (x, y) = (0, 0), \end{cases}$$

and

$$\frac{\partial f}{\partial y}(x, y) = \begin{cases} x \frac{x^4 - 4x^2y^2 - y^4}{(x^2 + y^2)^2}, & (x, y) \neq (0, 0), \\ 0, & (x, y) = (0, 0). \end{cases}$$

Therefore, by using the polar coordinates, we obtain:

$$\lim_{(x,y) \rightarrow (0,0)} \frac{\partial f}{\partial x}(x, y) = \lim_{(x,y) \rightarrow (0,0)} y \frac{x^4 + 4x^2y^2 - y^4}{(x^2 + y^2)^2} = 0,$$

and

$$\lim_{(x,y) \rightarrow (0,0)} \frac{\partial f}{\partial y}(x, y) = \lim_{(x,y) \rightarrow (0,0)} x \frac{x^4 - 4x^2y^2 - y^4}{(x^2 + y^2)^2} = 0.$$

Therefore, f is of class \mathcal{C}^1 on \mathbb{R}^2 . However, noticing that

$$\frac{\partial^2 f}{\partial y \partial x}(0, 0) = \lim_{h \rightarrow 0} \frac{\frac{\partial f}{\partial x}(0, h) - \frac{\partial f}{\partial x}(0, 0)}{h} = \lim_{h \rightarrow 0} -\frac{h}{h} = -1,$$

and

$$\frac{\partial^2 f}{\partial x \partial y}(0, 0) = \lim_{h \rightarrow 0} \frac{\frac{\partial f}{\partial y}(h, 0) - \frac{\partial f}{\partial y}(0, 0)}{h} = \lim_{h \rightarrow 0} \frac{h}{h} = 1,$$

and obviously, $\frac{\partial^2 f}{\partial y \partial x}(0, 0) \neq \frac{\partial^2 f}{\partial x \partial y}(0, 0)$.

Corollary 2.5. *Suppose that $f \in \mathcal{C}^k(\mathcal{D})$. Then all partial derivatives up to order k can be interchanged.*

3 Chain rules

If $f : \mathbb{R}^n \rightarrow \mathbb{R}^m$ and $g : \mathbb{R}^k \rightarrow \mathbb{R}^n$, then there exists a composite function $h : \mathbb{R}^k \rightarrow \mathbb{R}^m$ defined by $h(x) = f(g(x))$, and also we can write $h = f \circ g$.

The chain gives a formula for the derivatives of the composite function h in terms of the derivatives of f and g . We start with some special cases:

• $k = m = 1$, and $n = 2$. In this case, we have $f : \mathbb{R}^2 \rightarrow \mathbb{R}$, $(x, y) \mapsto z = f(x, y)$ and $g : \mathbb{R} \rightarrow \mathbb{R}^2$, $t \mapsto (g_1(t), g_2(t))$. Therefore, we have $h : \mathbb{R} \rightarrow \mathbb{R}$, $t \mapsto z = h(t) = f(g_1(t), g_2(t))$. Then, we have the following theorem:

Theorem 3.1. *If f and g are differentiable functions, then so is the composite $h = f \circ g$, and the derivative is given by*

$$\frac{dh(t)}{dt} = \frac{dg_1}{dt}(t) \frac{\partial f}{\partial x}(g_1(t), g_2(t)) + \frac{dg_2}{dt}(t) \frac{\partial f}{\partial y}(g_1(t), g_2(t)).$$

Example 3.2. *Given $z = f(x, y) = x^2 + y^2 + xy$, with $x = \sqrt{t}$ and $y = \cos t$. Evaluate $\frac{dz}{dt}$.*

We have

$$\begin{aligned}\frac{dz}{dt} &= \frac{\partial f}{\partial x} \frac{dx}{dt} + \frac{\partial f}{\partial y} \frac{dy}{dt} \\ &= (2x + y) \frac{1}{2\sqrt{t}} - (x + 2y) \sin t \\ &= \left(1 + \frac{\cos t}{2\sqrt{t}}\right) - (\sqrt{t} + 2 \cos t) \sin t.\end{aligned}$$

Example 3.3. Consider $z = f(x, y) = x^2y + 3xy^4$, with $x = \sin(2t)$ and $y = \cos t$. Evaluate $\frac{dz}{dt}$ at $t = 0$.

We have

$$\begin{aligned}\frac{dz}{dt} &= \frac{\partial f}{\partial x} \frac{dx}{dt} + \frac{\partial f}{\partial y} \frac{dy}{dt} \\ &= 2(2xy + 3y^4) \cos(2t) - (x^2 + 12xy^3) \sin t. \\ &= \end{aligned}$$

Note that, if $t = 0$, it follows that $x = 0$ and $y = 1$. Then, we have

$$\left. \frac{dz}{dt} \right|_{t=0} = 6.$$

• $k = m = 1$, with $n \geq 2$. In this case, we have $z = f(x_1, x_2, \dots, x_n)$, with $x_1 = g_1(t), x_2 = g_2(t), \dots, x_n = g_n(t)$ and the composite is given by

$$z = h(t) = f(g_1(t), g_2(t), \dots, g_n(t)).$$

Therefore, the chain rules says:

$$\frac{dh(t)}{dt} = \frac{dg_1(t)}{dt} \frac{\partial f}{\partial x_1} + \frac{dg_2(t)}{dt} \frac{\partial f}{\partial x_2} + \dots + \frac{dg_n(t)}{dt} \frac{\partial f}{\partial x_n}.$$

$k = m = n = 2$. In this case, we have $f : \mathbb{R}^2 \rightarrow \mathbb{R}^2$, $(x, y) \mapsto (z_1, z_2)$ with $z_1 = f_1(x, y)$ and $z_2 = f_2(x, y)$. Moreover, we have $g : \mathbb{R}^2 \rightarrow \mathbb{R}^2$, $(t, s) \mapsto (x, y)$, with $x = g_1(t, s)$ and $y = g_2(t, s)$. Therefore, the composite $h : \mathbb{R}^2 \rightarrow \mathbb{R}^2$, $(t, s) \mapsto (z_1, z_2)$ is expressed as

$$\begin{aligned}z_1 &= h_1(t, s) = f_1(g_1(t, s), g_2(t, s)), \\ z_2 &= h_2(t, s) = f_2(g_1(t, s), g_2(t, s)).\end{aligned}$$

Thus, we have

$$\begin{aligned}\frac{\partial z_1}{\partial t} &= \frac{\partial h_1}{\partial t}(t, s) = \frac{\partial g_1}{\partial t}(t, s) \frac{\partial f_1}{\partial x}(t, s) + \frac{\partial g_2}{\partial t}(t, s) \frac{\partial f_1}{\partial y}(t, s), \\ \frac{\partial z_1}{\partial s} &= \frac{\partial h_1}{\partial s}(t, s) = \frac{\partial g_1}{\partial s}(t, s) \frac{\partial f_1}{\partial x}(t, s) + \frac{\partial g_2}{\partial s}(t, s) \frac{\partial f_1}{\partial y}(t, s), \\ \frac{\partial z_2}{\partial t} &= \frac{\partial h_2}{\partial t}(t, s) = \frac{\partial g_1}{\partial t}(t, s) \frac{\partial f_2}{\partial x}(t, s) + \frac{\partial g_2}{\partial t}(t, s) \frac{\partial f_2}{\partial y}(t, s), \\ \frac{\partial z_2}{\partial s} &= \frac{\partial h_2}{\partial s}(t, s) = \frac{\partial g_1}{\partial s}(t, s) \frac{\partial f_2}{\partial x}(t, s) + \frac{\partial g_2}{\partial s}(t, s) \frac{\partial f_2}{\partial y}(t, s).\end{aligned}$$

This can also be written as a matrix product as follows:

$$\begin{pmatrix} \frac{\partial z_1}{\partial t} & \frac{\partial z_1}{\partial s} \\ \frac{\partial z_2}{\partial t} & \frac{\partial z_2}{\partial s} \end{pmatrix} = \begin{pmatrix} \frac{\partial z_1}{\partial x} & \frac{\partial z_1}{\partial y} \\ \frac{\partial z_2}{\partial x} & \frac{\partial z_2}{\partial y} \end{pmatrix} \begin{pmatrix} \frac{\partial x}{\partial t} & \frac{\partial x}{\partial s} \\ \frac{\partial y}{\partial t} & \frac{\partial y}{\partial s} \end{pmatrix},$$

which is equivalently

$$\mathbf{J}(h)(t, s) = \mathbf{J}(f)(g_1(t, s), g_2(t, s))\mathbf{J}(g)(t, s).$$

In the general the case, if $f : \mathbb{R}^n \rightarrow \mathbb{R}^m$ and $g : \mathbb{R}^k \rightarrow \mathbb{R}^n$ are differentiable then the composite function $h = f \circ g : \mathbb{R}^k \rightarrow \mathbb{R}^m$ is differentiable and

$$\underbrace{\mathbf{J}(h)(x)}_{m \times k \text{ matrix}} = \underbrace{\mathbf{J}(f)(g(x))}_{m \times n \text{ matrix}} \underbrace{\mathbf{J}(g)(x)}_{n \times k \text{ matrix}}.$$

In other words the derivative of a composite is the matrix product of the derivatives of the two elements. All forms of the chain rule are special cases of this equation

Example 3.4. Consider $f : \mathbb{R}^3 \rightarrow \mathbb{R}$ given by $f(x, y, z) = xyz$ and $g : \mathbb{R}^2 \rightarrow \mathbb{R}^3$ defined as $g(t, s) = (t^2s, 1, e^{ts})$.

Find the partial derivatives of $h = (f \circ g)(t, s)$.

Consider $x = t^2s$, $y = 1$ and $z = e^{ts}$. Therefore, it yields

$$\begin{aligned} \frac{\partial h}{\partial t}(t, s) &= \frac{\partial g_1(t, s)}{\partial t} \frac{\partial f}{\partial x}(t, s) + \cancel{\frac{\partial g_2(t, s)}{\partial t} \frac{\partial f}{\partial y}(t, s)} + \frac{\partial g_3(t, s)}{\partial t} \frac{\partial f}{\partial z}(t, s) \\ &= 2tse^{ts} + t^2s^2e^{st}. \end{aligned}$$

Analogously, we find

$$\begin{aligned} \frac{\partial h}{\partial s}(t, s) &= \frac{\partial g_1(t, s)}{\partial s} \frac{\partial f}{\partial x}(t, s) + \cancel{\frac{\partial g_2(t, s)}{\partial s} \frac{\partial f}{\partial y}(t, s)} + \frac{\partial g_3(t, s)}{\partial s} \frac{\partial f}{\partial z}(t, s) \\ &= t^2e^{ts} + t^3se^{st}. \end{aligned}$$

We can also write

$$\underbrace{\mathbf{J}(h)(t, s)}_{1 \times 2 \text{ matrix}} = \underbrace{\mathbf{J}(f)(g(t, s))}_{1 \times 3 \text{ matrix}} \underbrace{\mathbf{J}(g)(t, s)}_{3 \times 2 \text{ matrix}},$$

equivalently,

$$\begin{aligned} \left(\frac{\partial h}{\partial t}(t, s), \frac{\partial h}{\partial s}(t, s) \right) &= \left(\frac{\partial f}{\partial x}g(t, s), \frac{\partial f}{\partial y}g(t, s), \frac{\partial f}{\partial z}g(t, s) \right) \begin{pmatrix} \frac{\partial g_1}{\partial t}(t, s) & \frac{\partial g_1}{\partial s}(t, s) \\ \frac{\partial g_2}{\partial t}(t, s) & \frac{\partial g_2}{\partial s}(t, s) \\ \frac{\partial g_3}{\partial t}(t, s) & \frac{\partial g_3}{\partial s}(t, s) \end{pmatrix} \\ &= (e^{ts}, t^2s^{ts}, t^2s) \begin{pmatrix} 2ts & t^2 \\ 0 & 0 \\ se^{ts} & te^{ts} \end{pmatrix} \\ &= (2tse^{ts} + t^2s^2e^{st}, t^2e^{ts} + t^3se^{st}). \end{aligned}$$

4 Exercises

Exercise 4.1. *Given*

$$f(x, y) = \begin{cases} \frac{x^2 y^3}{(x^2 + y^2)^2}, & (x, y) \neq (0, 0), \\ 0, & (x, y) = (0, 0). \end{cases}$$

Evaluates the partial derivatives of f on \mathbb{R}^2 .

Let $(x, y) \in \mathbb{R}^2 \setminus \{(0, 0)\}$. Then, the partial derivative of f with respect to x is

$$\frac{\partial f}{\partial x}(x, y) = \frac{2xy^3(y^2 - x^2)}{(x^2 + y^2)^2}.$$

Furthermore, the partial derivative of f with respect to y is given by

$$\frac{\partial f}{\partial y}(x, y) = \frac{x^2 y^2(3x^2 - y^2)}{(x^2 + y^2)^2}.$$

Next, if $(x, y) = (0, 0)$, we have

$$\frac{\partial f}{\partial x}(0, 0) = \lim_{h \rightarrow 0} \frac{f(h, 0) - f(0, 0)}{h} = \lim_{h \rightarrow 0} \frac{\frac{h^2 0^3}{(h^2 + 0)^2} - 0}{h} = 0.$$

In a similar way, we can get

$$\frac{\partial f}{\partial y}(0, 0) = 0.$$

Hence, we write

$$\frac{\partial f}{\partial x}(x, y) = \begin{cases} \frac{2xy^3(y^2 - x^2)}{(x^2 + y^2)^2}, & (x, y) \neq (0, 0), \\ 0, & (x, y) = (0, 0), \end{cases}$$

and

$$\frac{\partial f}{\partial y}(x, y) = \begin{cases} \frac{x^2 y^2(3x^2 - y^2)}{(x^2 + y^2)^2}, & (x, y) \neq (0, 0), \\ 0, & (x, y) = (0, 0), \end{cases}$$

Exercise 4.2. *Consider the function f given by*

$$f(x, y) = \begin{cases} 2x^2 y \sin\left(\frac{1}{y^2}\right), & y \neq 0, \\ 0, & y = 0. \end{cases}$$

1. *Is f continuous function on all of \mathbb{R}^2 ?*
2. *Evaluate the partielle derivatives of f on \mathbb{R}^2 .*
3. *Study the continuity of $\frac{\partial f}{\partial x}$ and $\frac{\partial f}{\partial y}$ on \mathbb{R}^2 .*

Solution. 1. When $y \neq 0$, the function f is continuous since it is written as the product of two continuous functions on $\mathbb{R} \times \mathbb{R} \setminus \{0\}$.

Let $y = 0$. Then, f is continuous function at the point $(x_0, 0)$ if

$$\lim_{(x,y) \rightarrow (x_0,0)} f(x,y) = f(x_0, 0) = 0.$$

We have

$$0 \leq \left| 2x^2y \sin\left(\frac{1}{y^2}\right) \right| \leq 2x^2|y|, \quad (\text{since } \left| \sin\left(\frac{1}{y^2}\right) \right| \leq 1).$$

Next, by passing to the limit as (x, y) approaches $(x_0, 0)$, we can find

$$0 \leq \lim_{(x,y) \rightarrow (x_0,0)} \left| 2x^2y \sin\left(\frac{1}{y^2}\right) \right| \leq \lim_{(x,y) \rightarrow (x_0,0)} 2x^2|y| \rightarrow 0$$

Then, by squeeze principle it yields

$$\lim_{(x,y) \rightarrow (x_0,0)} 2x^2y \sin\left(\frac{1}{y^2}\right) = f(x_0, 0) = 0,$$

which implies that f is continuous function at the point $(x_0, 0)$.

2. If $y \neq 0$, we have

$$\frac{\partial f}{\partial x}(x, y) = 4xy \sin\left(\frac{1}{y^2}\right),$$

and

$$\frac{\partial f}{\partial x}(x, y) = 2x^2 \left[\sin\left(\frac{1}{y^2}\right) + \cos\left(\frac{1}{y^2}\right) \right].$$

If $y = 0$, we have by definition

$$\begin{aligned} \frac{\partial f}{\partial x}(x_0, 0) &= \lim_{h \rightarrow 0} \frac{f(x_0 + h, 0) - \cancel{f(x_0, 0)}}{h} \\ &= \lim_{h \rightarrow 0} \frac{2(x_0 + h)^2 \cdot 0 \cdot \sin\left(\frac{1}{0}\right)}{h} \\ &= 0, \end{aligned}$$

and

$$\begin{aligned} \frac{\partial f}{\partial y}(x_0, 0) &= \lim_{h \rightarrow 0} \frac{f(x_0, 0 + h) - \cancel{f(x_0, 0)}}{h} \\ &= \lim_{h \rightarrow 0} \frac{2x_0^2 \cdot (0 + h) \cdot \sin\left(\frac{1}{h}\right)}{h} \\ &= 0. \end{aligned}$$

Consequently, we have

$$\frac{\partial f}{\partial x}(x, y) = \begin{cases} 4xy \sin\left(\frac{1}{y^2}\right), & y \neq 0, \\ 0, & y = 0, \end{cases}$$

and

$$\frac{\partial f}{\partial y}(x, y) = \begin{cases} 2x^2 \left[\sin\left(\frac{1}{y^2}\right) + \cos\left(\frac{1}{y^2}\right) \right], & y \neq 0, \\ 0, & y = 0. \end{cases}$$

Exercise 4.3. Verify that $f : \mathbb{R}^2 \times (0, +\infty) \rightarrow \mathbb{R}$ given by

$$f(x, y, t) = \frac{1}{2\pi t} e^{-\frac{x^2+y^2}{4t}}$$

satisfies the heat equation: $\frac{\partial f}{\partial t} = \frac{\partial^2 f}{\partial x^2} + \frac{\partial^2 f}{\partial y^2}$.

Solution. Firstly, we have

$$\frac{\partial f}{\partial t} = \frac{1}{2\pi} \left(-\frac{1}{t^2} + \frac{x^2+y^2}{4t^2} \right) e^{-\frac{x^2+y^2}{4t}}.$$

Moreover, we have

$$\frac{\partial f}{\partial x} = -\frac{x}{4\pi t^2} e^{-\frac{x^2+y^2}{4t}}.$$

Therefore, we can get

$$\frac{\partial^2 f}{\partial x^2} = \frac{1}{2\pi} \left(-\frac{1}{2t^2} + \frac{x^2}{4t^2} \right) e^{-\frac{x^2+y^2}{4t}}.$$

Similarly, it yields that

$$\frac{\partial^2 f}{\partial y^2} = \frac{1}{2\pi} \left(-\frac{1}{2t^2} + \frac{y^2}{4t^2} \right) e^{-\frac{x^2+y^2}{4t}}.$$

Thus, it follows

$$\frac{\partial^2 f}{\partial x^2} + \frac{\partial^2 f}{\partial y^2} = \frac{1}{2\pi} \left(-\frac{1}{t^2} + \frac{x^2+y^2}{4t^2} \right) e^{-\frac{x^2+y^2}{4t}},$$

which implies that f is satisfying the two dimensional heat equation.

Exercise 4.4. Given

$$f(x, y) = \begin{cases} \frac{y^4}{x^2+y^2}, & (x, y) \neq (0, 0) \\ 0, & (x, y) = (0, 0). \end{cases}$$

1. Prove that f is of class \mathcal{C}^1 on \mathbb{R}^2 .
2. Show that $\frac{\partial^2 f}{\partial x \partial y}(0, 0)$ and $\frac{\partial^2 f}{\partial y \partial x}(0, 0)$ exist.
3. Show that $\frac{\partial^2 f}{\partial x \partial y}$ and $\frac{\partial^2 f}{\partial y \partial x}$ are not continuous functions at origin.

Solution. 1. Firstly, it is obvious to see that f is of class \mathcal{C}^1 function on $\mathbb{R}^2 \setminus \{(0, 0)\}$ because f is expressed as a quotient of two \mathcal{C}^1 functions and the denominator does not

vanish. Moreover, for any $(x, y) \neq (0, 0)$, we have

$$\frac{\partial f}{\partial x}(x, y) = -\frac{2xy^4}{(x^2 + y^2)^2},$$

and

$$\frac{\partial f}{\partial y}(x, y) = \frac{2y^3(2x^2 + y^2)}{(x^2 + y^2)^2}.$$

Next, we move to show that f is of class \mathcal{C}^1 function at $(0, 0)$. To do that, we need to show that the partial derivatives of f are continuous at $(0, 0)$. So, we need to evaluate $\frac{\partial f}{\partial x}$ and $\frac{\partial f}{\partial y}$ at the point $(0, 0)$. Thus, we have

$$\frac{\partial f}{\partial x}(0, 0) = \lim_{h \rightarrow 0} \frac{f(h, 0) - \cancel{f(0, 0)}^0}{h} = \lim_{h \rightarrow 0} \frac{h^4}{h^2 + 0^2} = \lim_{h \rightarrow 0} \frac{0}{h} = 0,$$

and

$$\frac{\partial f}{\partial y}(0, 0) = \lim_{h \rightarrow 0} \frac{f(0, h) - \cancel{f(0, 0)}^0}{h} = \lim_{h \rightarrow 0} \frac{h^4}{0^2 + h^2} = \lim_{h \rightarrow 0} \frac{h^4}{h^2} = 0.$$

On the other hand, we have

$$\begin{aligned} 0 \leq \left| \frac{\partial f}{\partial x}(x, y) \right| &= \frac{2|x|y^4}{(x^2 + y^2)^2} \\ &\leq \frac{2\sqrt{x^2 + y^2}(x^2 + y^2)^2}{(x^2 + y^2)^2} \\ &= 2\sqrt{x^2 + y^2}, \end{aligned}$$

where we have used $|x| \leq \sqrt{x^2 + y^2}$ and $y^4 \leq (x^2 + y^2)^2$. Therefore, it follows that

$$0 \leq \lim_{(x, y) \rightarrow (0, 0)} \left| \frac{\partial f}{\partial x}(x, y) \right| \leq \lim_{(x, y) \rightarrow (0, 0)} 2\sqrt{x^2 + y^2} = 0.$$

Thus, by squeeze principle, it yields that $\lim_{(x, y) \rightarrow (0, 0)} \frac{\partial f}{\partial x}(x, y) = 0$. Moreover, we have

$$\begin{aligned} 0 \leq \left| \frac{\partial f}{\partial y}(x, y) \right| &= \frac{2|x|^3(2x^2 + 2y^2)}{(x^2 + y^2)^2} \\ &\leq \frac{4\sqrt{x^2 + y^2}(x^2 + y^2)^2}{(x^2 + y^2)^2} \\ &= 4\sqrt{x^2 + y^2}. \end{aligned}$$

Similar as before, we can show that $\lim_{(x, y) \rightarrow (0, 0)} \frac{\partial f}{\partial y}(x, y) = 0$. Consequently, f is also \mathcal{C}^1 function at $(0, 0)$. In conclusion, f is \mathcal{C}^1 function on \mathbb{R}^2 .

2. We have

$$\frac{\partial^2 f}{\partial x \partial y}(0, 0) = \frac{\partial}{\partial x} \left(\frac{\partial f}{\partial y} \right) (0, 0) = \lim_{h \rightarrow 0} \frac{\frac{\partial f}{\partial y}(h, 0) - \cancel{\frac{\partial f}{\partial y}(0, 0)}^0}{h} = \lim_{h \rightarrow 0} \frac{\frac{2 \cdot 0^3 \cdot (2h^2 + 0^2)}{(h^2 + 0^2)^2}}{h} = \lim_{h \rightarrow 0} \frac{0}{h} = 0.$$

Similarly, we have

$$\frac{\partial^2 f}{\partial y \partial x}(0, 0) = \frac{\partial}{\partial y} \left(\frac{\partial f}{\partial x} \right) (0, 0) = \lim_{h \rightarrow 0} \frac{\frac{\partial f}{\partial x}(0, h) - \frac{\partial f}{\partial x}(0, 0)}{h} = \lim_{h \rightarrow 0} \frac{\frac{-2h^2 - 0^4}{(0^2 + h^2)^2}}{h} = \lim_{h \rightarrow 0} \frac{0}{h} = 0.$$

Hence, $\frac{\partial^2 f}{\partial x \partial y}(0, 0)$ and $\frac{\partial^2 f}{\partial y \partial x}(0, 0)$ exist and they coincide (i.e., $\frac{\partial^2 f}{\partial x \partial y}(0, 0) = \frac{\partial^2 f}{\partial y \partial x}(0, 0) = 0$).

3. For any, $(x, y) \neq (0, 0)$, we have

$$\frac{\partial^2 f}{\partial x \partial y}(x, y) = \frac{\partial^2 f}{\partial y \partial x}(x, y) = -\frac{8x^3 y^3}{(x^2 + y^2)^3}.$$

Furthermore, approaching the limit along the line $y = x$, it yields the following

$$\lim_{(x,y) \rightarrow (0,0)} \frac{\partial^2 f}{\partial x \partial y}(x, y) = \lim_{x \rightarrow 0} -\frac{x^6}{x^6} = -1 \neq 0.$$

Hence, the functions $\frac{\partial^2 f}{\partial x \partial y}$ and $\frac{\partial^2 f}{\partial y \partial x}$ are not continuous at the point $(0, 0)$.

Exercise 4.5. Let f be of class \mathcal{C}^2 function, and consider $g : \mathbb{R}^2 \rightarrow \mathbb{R}$ given by

$$g(u, v) = f(u + v, u - v).$$

Evaluate $\frac{\partial^2 g}{\partial u \partial v}(u, v)$.

Solution. Setting $\mathbf{u} = u + v$ and $\mathbf{v} = u - v$. Then, we have

$$\begin{aligned} \frac{\partial g}{\partial u} &= \frac{\partial \mathbf{u}}{\partial u} \frac{\partial f}{\partial \mathbf{u}}(u + v, u - v) + \frac{\partial \mathbf{v}}{\partial u} \frac{\partial f}{\partial \mathbf{v}}(u + v, u - v) \\ &= \frac{\partial f}{\partial \mathbf{u}}(u + v, u - v) + \frac{\partial f}{\partial \mathbf{v}}(u + v, u - v), \end{aligned}$$

and

$$\begin{aligned} \frac{\partial g}{\partial v} &= \frac{\partial \mathbf{u}}{\partial v} \frac{\partial f}{\partial \mathbf{u}}(u + v, u - v) + \frac{\partial \mathbf{v}}{\partial v} \frac{\partial f}{\partial \mathbf{v}}(u + v, u - v) \\ &= \frac{\partial f}{\partial \mathbf{u}}(u + v, u - v) - \frac{\partial f}{\partial \mathbf{v}}(u + v, u - v). \end{aligned}$$

Therefore, it yields that

$$\begin{aligned}
 \frac{\partial^2 g}{\partial u \partial v}(u, v) &= \frac{\partial}{\partial u} \left(\frac{\partial g}{\partial v} \right) (u, v) \\
 &= \frac{\partial}{\partial u} \left(\frac{\partial f}{\partial \mathbf{u}}(u+v, u-v) - \frac{\partial f}{\partial \mathbf{v}}(u+v, u-v) \right) \\
 &= \cancel{\frac{\partial \mathbf{u}^1}{\partial u} \frac{\partial^2 f}{\partial \mathbf{u}^2}}(u+v, u-v) + \cancel{\frac{\partial \mathbf{v}^1}{\partial u} \frac{\partial^2 f}{\partial \mathbf{v} \partial \mathbf{u}}}(u+v, u-v) \\
 &\quad - \cancel{\frac{\partial \mathbf{u}^1}{\partial u} \frac{\partial^2 f}{\partial \mathbf{u} \partial \mathbf{v}}}(u+v, u-v) - \cancel{\frac{\partial \mathbf{v}^1}{\partial u} \frac{\partial^2 f}{\partial \mathbf{v}^2}}(u+v, u-v) \\
 &= \frac{\partial^2 f}{\partial \mathbf{u}^2}(u+v, u-v) + \frac{\partial^2 f}{\partial \mathbf{v} \partial \mathbf{u}}(u+v, u-v) \\
 &\quad - \frac{\partial^2 f}{\partial \mathbf{u} \partial \mathbf{v}}(u+v, u-v) - \frac{\partial^2 f}{\partial \mathbf{v}^2}(u+v, u-v).
 \end{aligned}$$

Since $f \in \mathcal{C}^2$, by Schwarz Theorem, we can observe that $\frac{\partial^2 f}{\partial \mathbf{v} \partial \mathbf{u}} = \frac{\partial^2 f}{\partial \mathbf{u} \partial \mathbf{v}}$. Consequently, it results:

$$\frac{\partial^2 g}{\partial u \partial v}(u, v) = \frac{\partial^2 f}{\partial \mathbf{u}^2}(u+v, u-v) - \frac{\partial^2 f}{\partial \mathbf{v}^2}(u+v, u-v).$$

Exercise 4.6. Let f be of class \mathcal{C}^2 , and $g : \mathbb{R}^3 \rightarrow \mathbb{R}$ be defined by $g(x, y, z) = f(u(x, y, z), v(x, y, z))$ with $u = \frac{y^2-x}{xy^2}$ and $v = \frac{z^3-x}{xz^3}$.

1. Demonstrate that

$$x^2 \frac{\partial g}{\partial x} + \frac{y^3}{2} \frac{\partial g}{\partial y} + \frac{z^4}{3} \frac{\partial g}{\partial z} = 0.$$

2. Assume that f satisfies $\frac{\partial^2 f}{\partial u^2} + 2 \frac{\partial^2 f}{\partial u \partial v} + \frac{\partial^2 f}{\partial v^2} = 0$. Express g in term of x, y, z and the first partial derivatives of f .

Solution. Firstly, we have

$$\begin{aligned}
 \frac{\partial g}{\partial x} &= \frac{\partial u}{\partial x} \frac{\partial f}{\partial u}(u, v) + \frac{\partial v}{\partial x} \frac{\partial f}{\partial v}(u, v) \\
 &= -\frac{1}{x^2} \frac{\partial f}{\partial u} - \frac{1}{x^2} \frac{\partial f}{\partial v}.
 \end{aligned}$$

Thus, we have

$$\frac{\partial g}{\partial x} = -\frac{1}{x^2} \left(\frac{\partial f}{\partial u}(u, v) + \frac{\partial f}{\partial v}(u, v) \right).$$

Next, it follows

$$\begin{aligned}
 \frac{\partial g}{\partial y} &= \frac{\partial u}{\partial y} \frac{\partial f}{\partial u}(u, v) + \frac{\partial v}{\partial y} \frac{\partial f}{\partial v}(u, v) \\
 &= \frac{2}{y^3} \frac{\partial f}{\partial u} + 0 \cdot \cancel{\frac{\partial f}{\partial v}}^0,
 \end{aligned}$$

and hence, we have

$$\frac{\partial g}{\partial x} = \frac{2}{y^3} \frac{\partial f}{\partial u}(u, v).$$

Similarly, we find

$$\frac{\partial g}{\partial z} = \frac{3}{z^4} \frac{\partial f}{\partial v}.$$

Therefore, it yields

$$\begin{aligned} x^2 \frac{\partial g}{\partial x} + \frac{y^3}{2} \frac{\partial g}{\partial y} + \frac{z^4}{3} \frac{\partial g}{\partial z} &= - \left(\frac{\partial f}{\partial u} + \frac{\partial f}{\partial v} \right) + \frac{\partial f}{\partial u} + \frac{\partial f}{\partial v} \\ &= 0. \end{aligned}$$

2. We have

$$\frac{\partial g}{\partial x} = -\frac{1}{x^2} \left(\frac{\partial f}{\partial u}(u, v) + \frac{\partial f}{\partial v}(u, v) \right).$$

Then, it follows that

$$\frac{\partial^2 g}{\partial x^2} = \frac{2}{x^2} \left(\frac{\partial f}{\partial u} + \frac{\partial f}{\partial v} \right) - \frac{1}{x^2} \left[\frac{\partial u}{\partial x} \frac{\partial^2 f}{\partial u^2} + \frac{\partial v}{\partial x} \frac{\partial^2 f}{\partial v \partial u} + \frac{\partial u}{\partial x} \frac{\partial^2 f}{\partial u \partial v} + \frac{\partial v}{\partial x} \frac{\partial^2 f}{\partial v^2} \right]$$

Noticing that $\frac{\partial u}{\partial x} = \frac{\partial v}{\partial x} = -\frac{1}{x^2}$, and from Schwarz Lemma, we have $\frac{\partial^2 f}{\partial u \partial v} = \frac{\partial^2 f}{\partial v \partial u}$. Therefore, we can get

$$\begin{aligned} \frac{\partial^2 g}{\partial x^2} &= \frac{2}{x^3} \left(\frac{\partial f}{\partial u} + \frac{\partial f}{\partial v} \right) - \frac{1}{x^4} \left(\frac{\partial^2 f}{\partial u^2} + 2 \frac{\partial^2 f}{\partial u \partial v} + \frac{\partial^2 f}{\partial v^2} \right) \\ &= \frac{2}{x^3} \left(\frac{\partial f}{\partial u} + \frac{\partial f}{\partial v} \right). \end{aligned}$$

Exercise 4.7. Let $f : \mathbb{R}^2 \rightarrow \mathbb{R}$ be of class C^1 such that

$$\Delta f(x, y) = \frac{\partial^2 f}{\partial x^2}(x, y) + \frac{\partial^2 f}{\partial y^2}(x, y) = 0, \quad \text{for all } (x, y) \in \mathbb{R}^2.$$

Consider $z : \mathbb{R}^2 \rightarrow \mathbb{R}$ given by

$$z(u, v) = e^u \cos v + f(u + v, u - v).$$

Evaluate $\Delta z(u, v)$ for all $(x, y) \in \mathbb{R}^2$.

Solution. Suppose $x = u + v$ and $y = u - v$. Then, it follows

$$\begin{aligned} \frac{\partial z}{\partial u}(u, v) &= e^u \cos v + \frac{\partial x}{\partial u} \frac{\partial f}{\partial x} + \frac{\partial y}{\partial u} \frac{\partial f}{\partial y} \\ &= e^u \cos v + \frac{\partial f}{\partial x}(u, v) + \frac{\partial f}{\partial y}(u, v), \end{aligned}$$

and

$$\begin{aligned}\frac{\partial^2 z}{\partial u^2}(u, v) &= e^u \cos v + \frac{\partial x}{\partial u} \frac{\partial^2 f}{\partial x^2} + \frac{\partial y}{\partial u} \frac{\partial^2 f}{\partial y \partial x} + \frac{\partial x}{\partial u} \frac{\partial^2 f}{\partial x \partial y} + \frac{\partial y}{\partial u} \frac{\partial^2 f}{\partial y^2} \\ &= e^u \cos v + \frac{\partial^2 f}{\partial x^2}(u, v) + 2 \frac{\partial^2 f}{\partial x \partial y}(u, v) + \frac{\partial^2 f}{\partial y^2}(u, v).\end{aligned}$$

Analogously, we can find

$$\begin{aligned}\frac{\partial z}{\partial v} &= -e^u \sin v + \frac{\partial x}{\partial v} \frac{\partial f}{\partial x} + \frac{\partial y}{\partial v} \frac{\partial f}{\partial y} \\ &= -e^u \sin v + \frac{\partial f}{\partial x}(u, v) - \frac{\partial f}{\partial y}(u, v),\end{aligned}$$

and

$$\begin{aligned}\frac{\partial^2 z}{\partial v^2}(u, v) &= -e^u \cos v + \frac{\partial x}{\partial v} \frac{\partial^2 f}{\partial x^2} + \frac{\partial y}{\partial v} \frac{\partial^2 f}{\partial y \partial x} - \frac{\partial x}{\partial v} \frac{\partial^2 f}{\partial x \partial y} - \frac{\partial y}{\partial v} \frac{\partial^2 f}{\partial y^2} \\ &= -e^u \cos v + \frac{\partial^2 f}{\partial x^2}(u, v) - 2 \frac{\partial^2 f}{\partial x \partial y}(u, v) + \frac{\partial^2 f}{\partial y^2}(u, v).\end{aligned}$$

Therefore, it follows that

$$\begin{aligned}\frac{\partial^2 z}{\partial u^2}(u, v) + \frac{\partial^2 z}{\partial v^2}(u, v) &= 2 \left(\frac{\partial^2 f}{\partial x^2}(u, v) + \frac{\partial^2 f}{\partial y^2}(u, v) \right) \\ &= 2\Delta f(x, y) \\ &= 0.\end{aligned}$$

In conclusion, we have $\Delta z(u, v) = 0$, for all $(u, v) \in \mathbb{R}^2$.

Exercise 4.8. Show that $u(x, y) = \frac{x^2 y^2}{x+y}$ satisfies the following partial differential equation:

$$x \frac{\partial u}{\partial x}(x, y) + y \frac{\partial u}{\partial y}(x, y) = 3u(x, y).$$

Chapter 5

Differentiability

1 Differentiability

Definition 1.1. Let I be an open interval of \mathbb{R} . A real-valued function $f : I \rightarrow \mathbb{R}$ is called differentiable at the point $a \in I$ if

$$\lim_{x \rightarrow a} \frac{f(x) - f(a)}{x - a}$$

exists. If the limit exists, we call it the derivative of the function f at the point a , denoted $f'(a)$.

Definition 1.2. Let \mathcal{D} be an open set of \mathbb{R}^n . The function $f : \mathcal{D} \rightarrow \mathbb{R}$ is differentiable at the point $x_0 \in \mathcal{D}$ if f has a good linear approximation near x_0 , (i.e., if a good linear approximation of f near the point x_0 exists).

A good linear approximation of f at x_0 is also called a linearization of f at x_0 .

Suppose that $f : I \rightarrow \mathbb{R}$ is differentiable at a in the sense of Definition 1.2. Then f has a linearization at the point a : there is a real number η such that the function $L(x)$ defined by

$$L(x) = f(x_0) + \eta(x - x_0)$$

is a good approximation of f near the point x_0 , i.e.,

$$\lim_{x \rightarrow a} \frac{f(x) - L(x)}{x - x_0} = 0.$$

Therefore, we have

$$\begin{aligned} 0 &= \lim_{x \rightarrow x_0} \frac{f(x) - f(x_0) - \eta(x - a)}{x - x_0} \\ &= \lim_{x \rightarrow x_0} \left[\frac{f(x) - f(x_0)}{x - x_0} - \eta \right]. \end{aligned}$$

On the other hand, we can write

$$\lim_{x \rightarrow a} \frac{f(x) - f(x_0)}{x - x_0} = \lim_{x \rightarrow a} \left[\frac{f(x) - f(x_0)}{x - x_0} - \eta \right] + \eta = \eta.$$

In other words, $\lim_{x \rightarrow a} \frac{f(x) - f(x_0)}{x - x_0}$ exists, so f is differentiable in the sense of Definition 1.1 and hence $\eta = f'(x_0)$. The linearization $L(x)$ of f at x_0 can therefore be rewritten as

$$L(x) = f(a) + f'(a)(x - a).$$

Note that the graph of L is the graph of the equation $y = f(a) + f'(a)(x - a)$ which is exactly the straight line tangent to the graph of $y = f(x)$ at $(a, f(a))$.

Conversely, let us assume that f is differentiable at the point a in the sense of definition 1.1. Let $L(x) = f(a) + f'(a)(x - a)$ be a linear approximation of f near x_0 , but is it a good approximation ?

Setting $x = a + h$. Then, we have

$$\begin{aligned} \lim_{h \rightarrow 0} \frac{f(x) - L(x)}{h} &= \lim_{h \rightarrow 0} \frac{f(a + h) - f(a) - hf'(a)}{h} \\ &= \lim_{h \rightarrow 0} \underbrace{\frac{f(a + h) - f(a)}{h}}_{f'(a)} - \lim_{h \rightarrow 0} f'(a) \\ &= f'(a) - f'(a) = 0, \end{aligned}$$

which is implying the definition of "good approximation" of f near x_0 . Therefore, f is differentiable at x_0 in the sense of Definition 1.2.

Let us try to extend the concept of a good linear approximation at a point of function of two variables.

Definition 1.3. Let \mathcal{D} be an open set of \mathbb{R}^2 . We say that $f : \mathcal{D} \rightarrow \mathbb{R}$ is differentiable at $(a, b) \in \mathcal{D}$ if f has a good linear approximation $L(x, y)$ near the point (a, b) , that is there exist $(\eta_1, \eta_2) \in \mathbb{R}^2$ such that

$$L(x, y) = f(a, b) + \eta_1(x - a) + \eta_2(y - b).$$

Because L is a good approximation of f near the point (a, b) , then we have

$$\lim_{(x,y) \rightarrow (a,b)} \frac{f(x, y) - f(a, b) - \eta_1(x - a) - \eta_2(y - b)}{\sqrt{(x - a)^2 + (y - b)^2}} = 0. \quad (5.1)$$

Approaching the limit (5.1) along the x -axis, (i.e., $x \rightarrow a$ and $y = b$), we then obtain

$$\lim_{x \rightarrow a} \frac{f(x, b) - f(a, b) - \eta_1(x - a)}{|x - a|} = 0,$$

which is implying that

$$\lim_{x \rightarrow a} \frac{f(x, b) - f(a, b)}{x - a} = \eta_1. \quad (5.2)$$

Note that the left-hand side of (5.2) is exactly the definition of $\frac{\partial f}{\partial x}(a, b)$. Therefore, it can be observed that this partial derivative exists and it has the value η_1 .

Similarly, by approaching the limit (5.1) along the y -axis, (i.e., $y \rightarrow b$ and $x = a$), we can

show that the partial derivative $\frac{\partial f}{\partial y}(a, b)$ exists and it has the value η_2 . Thus, f is differentiable at the point (a, b) if

$$\lim_{(x,y) \rightarrow (a,b)} \frac{f(x, y) - f(a, b) - \frac{\partial f}{\partial x}(a, b)(x - a) - \frac{\partial f}{\partial y}(a, b)(y - b)}{\sqrt{(x - a)^2 + (y - b)^2}} = 0. \quad (5.3)$$

Remark 1.4. Note that the limit (5.3) is implying that the graph of the function $f(x, y)$ coincides with the graph of the plane $L(x, y) = f(a, b) + \frac{\partial f}{\partial x}(a, b)(x - a) + \frac{\partial f}{\partial y}(a, b)(y - b)$ as (x, y) approaches the point (a, b) . Therefore, we can introduce the following definition:

Definition 1.5. Let \mathcal{D} be an open set of \mathbb{R}^2 . Let $f : \mathcal{D} \rightarrow \mathbb{R}$. Then, the plane in \mathbb{R}^3 defined by the equation

$$z(x, y) = f(a, b) + \frac{\partial f}{\partial x}(a, b)(x - a) + \frac{\partial f}{\partial y}(a, b)(y - b)$$

is called the tangent plane to the graph of function f at the point (a, b) .

Example 1.6. Find the equation of the tangent plane to the surface given by $z = 2x^2 - y^2 + 5y$ through the point $(-2, 2, 14)$.

Therefore, if f is differentiable at $x_0(a, b)$, the linearization L of the function f at the point $x_0 = (a, b)$ can be written as follows:

$$L(x, y) = f(a, b) + \frac{\partial f}{\partial x}(a, b)(x - a) + \frac{\partial f}{\partial y}(a, b)(y - b),$$

or equivalently as

$$L(x, y) = f(a, b) + \nabla f(a, b) \cdot (x - x_0).$$

Consequently, we can introduce the following definition of differentiability of functions of two variables:

Definition 1.7. Let \mathcal{D} be an open set of \mathbb{R}^2 . We say that $f : \mathcal{D} \rightarrow \mathbb{R}$ is differentiable at $x_0 = (a, b) \in \mathcal{D}$ if

$$\lim_{(x,y) \rightarrow (a,b)} \frac{f(x, y) - f(a, b) - \nabla f(a, b) \cdot (x - x_0)}{\sqrt{(x - a)^2 + (y - b)^2}} = 0.$$

Example 1.8. Given

$$f(x, y) = \begin{cases} (x^2 + y^2) \sin\left(\frac{1}{\sqrt{x^2 + y^2}}\right), & (x, y) \neq (0, 0), \\ 0, & (x, y) = (0, 0). \end{cases}$$

Then, f is differentiable at origin.

In view of Definition 1.7, f is differentiable at the point $(0, 0)$ if

$$\lim_{(x,y) \rightarrow (0,0)} \frac{f(x, y) - f(0, 0) - \frac{\partial f}{\partial x}(0, 0)x - \frac{\partial f}{\partial y}(0, 0)y}{\sqrt{x^2 + y^2}} = 0. \quad (5.4)$$

To end this, we will first calculate the partial derivatives $\frac{\partial f}{\partial x}(0, 0)$ and $\frac{\partial f}{\partial y}(0, 0)$. By the definition of the partial derivative with respect to x , we have

$$\begin{aligned} \frac{\partial f}{\partial x}(0, 0) &= \lim_{h \rightarrow 0} \frac{f(h, 0) - f(0, 0)}{h} \\ &= \lim_{h \rightarrow 0} \frac{(h^2 + 0) \sin\left(\frac{1}{\sqrt{h^2 + 0^2}}\right)}{h} \\ &= \lim_{h \rightarrow 0} h \sin\left(\frac{1}{|h|}\right) = 0, \end{aligned}$$

which follows from squeeze principle: $0 \leq \left| h \sin\left(\frac{1}{|h|}\right) \right| \leq |h| \xrightarrow{h \rightarrow 0} 0$, since $|\sin(u)| \leq 1$. Similarly, we have

$$\begin{aligned} \frac{\partial f}{\partial y}(0, 0) &= \lim_{h \rightarrow 0} \frac{f(0, h) - f(0, 0)}{h} \\ &= \lim_{h \rightarrow 0} \frac{(0 + h^2) \sin\left(\frac{1}{\sqrt{0 + h^2}}\right)}{h} \\ &= \lim_{h \rightarrow 0} h \sin\left(\frac{1}{|h|}\right) = 0. \end{aligned}$$

Now, since the partial derivatives exist, we pass the show that (5.4) holds. So, we have

$$\begin{aligned} \lim_{(x,y) \rightarrow (0,0)} \frac{f(x, y) - f(0, 0) - \frac{\partial f}{\partial x}(0, 0)x - \frac{\partial f}{\partial y}(0, 0)y}{\sqrt{x^2 + y^2}} &= \lim_{(x,y) \rightarrow (0,0)} \frac{f(x, y)}{\sqrt{x^2 + y^2}} \\ &= \lim_{(x,y) \rightarrow (0,0)} \sqrt{x^2 + y^2} \sin\left(\frac{1}{\sqrt{x^2 + y^2}}\right) \\ &= 0, \end{aligned}$$

by using the squeeze principle again: $0 \leq \left| \sqrt{x^2 + y^2} \sin\left(\frac{1}{\sqrt{x^2 + y^2}}\right) \right| \leq \sqrt{x^2 + y^2} \xrightarrow{(x,y) \rightarrow (0,0)} 0$. Hence, f is differentiable at the origin.

Similar to functions with one variable, we can state the following theorem that ensures that differentiability implies continuity.

Theorem 1.9. *Let \mathcal{D} be an open set of \mathbb{R}^n . If $f : \mathcal{D} \rightarrow \mathbb{R}$ is differentiable at $x_0 \in \mathcal{D}$, then f is continuous at x_0 .*

Theorem 1.10. *Let \mathcal{D} be an open set of \mathbb{R}^n . If $f : \mathcal{D} \rightarrow \mathbb{R}$ is differentiable at $x_0 \in \mathcal{D}$, then every partial derivative of the function f exists and is finite at x_0 .*

The analogy between differentiation for functions of one variable and for functions of several variable is not a total analogy. For functions of one variable if the derivative, $f'(x)$, can be computed, then the function f is differentiable at x_0 . The corresponding assertion for functions of two variables is false. which stands to reason after considering for a moment what it takes to compute the derivative, $\frac{\partial f}{\partial x}(x, y)$, $\frac{\partial f}{\partial y}(x, y)$, of a function of two variable. To find $\frac{\partial f}{\partial x}(a, b)$ one need only know the values of the function, f , along the x -axis, (i.e., $x \rightarrow a$, $y = b$) and to find $\frac{\partial f}{\partial y}(a, b)$ one need only know the values of f along the y -axis (i.e., $y \rightarrow b$ and $x = a$). Consequently, the values of f at points not on these two lines play no role in determining the derivative of f . However these values certainly are taken into account when determining whether or not f is differentiable at (a, b) ; that is, if the graph of f has a tangent plane at the point (a, b) . For example, let consider the function

$$f(x, y) = \begin{cases} \frac{xy}{x^2 + y^2}, & (x, y) \neq (0, 0), \\ 0, & (x, y) = (0, 0). \end{cases}$$

Note that the partial derivatives of f exist at the origin, that is

$$\frac{\partial f}{\partial x}(0, 0) = 0, \quad \text{and} \quad \frac{\partial f}{\partial y}(0, 0) = 0.$$

But f is not continuous at the point $(0, 0)$. Indeed, appraoching the limit of f along the line $y = x$, we obtain

$$\lim_{(x,y) \rightarrow (0,0)} f(x, y) = \lim_{t \rightarrow 0} f(t, t) = \lim_{t \rightarrow 0} \frac{t^2}{2t^2} = \frac{1}{2}.$$

On the other hand, if we approach the limit along the x -axis, we find

$$\lim_{(x,y) \rightarrow (0,0)} f(x, y) = \lim_{t \rightarrow 0} f(t, 0) = \lim_{t \rightarrow 0} \frac{t \cdot 0}{t^2 + 0^2} = 0.$$

Obviously, the two limits do not coincide, and hence f does not have a limit at the point $(0, 0)$. Therefore, f is not continuous function at this point and according to Theorem 1.9, f can't be differentiable at $(0, 0)$. You might suspect that if f is continuous at (a, b) and the first order partial derivatives exist there, then f may be differentiable at (a, b) but that conjecture is false as the following example shows. Let

$$f(x, y) = \begin{cases} \frac{xy}{\sqrt{x^2 + y^2}}, & (x, y) \neq (0, 0), \\ 0, & (x, y) = (0, 0). \end{cases}$$

The partial derivatives of f exist at $(0, 0)$, that is

$$\frac{\partial f}{\partial x}(0, 0) = 0, \quad \text{and} \quad \frac{\partial f}{\partial y}(0, 0) = 0.$$

Moreover, we have

$$\lim_{(x,y) \rightarrow (0,0)} f(x, y) = \lim_{(x,y) \rightarrow (0,0)} \frac{xy}{\sqrt{x^2 + y^2}} = \lim_{\substack{r \rightarrow 0 \\ \forall \theta}} r \cos \theta \sin \theta = 0,$$

which follows from squeeze principle : $0 \leq |r \cos \theta \sin \theta| \leq r \xrightarrow{r \rightarrow 0} 0$. Hence, f is continuous function at $(0, 0)$. However f can't be differentiable at $(0, 0)$. Indeed, we have

$$\lim_{(x,y) \rightarrow (0,0)} \frac{f(x,y) - f(0,0) - \frac{\partial f}{\partial x}(0,0)(x-0) - \frac{\partial f}{\partial y}(0,0)(y-0)}{\sqrt{(x-0)^2 + (y-0)^2}} = \lim_{(x,y) \rightarrow (0,0)} \frac{f(x,y)}{\sqrt{x^2 + y^2}}.$$

By evaluating the limit along the x -axis, we obtain

$$\lim_{(x,y) \rightarrow (0,0)} \frac{f(x,y)}{\sqrt{x^2 + y^2}} = \lim_{\substack{x \rightarrow 0 \\ y=0}} \frac{xy}{x^2 + y^2} = \lim_{\substack{x \rightarrow 0 \\ y=0}} \frac{x \cdot 0}{x^2 + 0^2} = 0,$$

and by approaching the limit along the line $y = x$, it results

$$\lim_{(x,y) \rightarrow (0,0)} \frac{f(x,y)}{\sqrt{x^2 + y^2}} = \lim_{\substack{x \rightarrow 0 \\ y=x}} \frac{xy}{x^2 + y^2} = \lim_{\substack{x \rightarrow 0 \\ y=x}} \frac{x \cdot x}{x^2 + x^2} = \frac{1}{2}.$$

Therefore, $\lim_{(x,y) \rightarrow (0,0)} \frac{f(x,y)}{\sqrt{x^2 + y^2}}$ does not exist and hence f is not differentiable at $(0, 0)$.

The natural question to ask then is under what conditions can we conclude that f is differentiable at (x, y) . The answer is contained in the following theorem:

Theorem 1.11. *Let \mathcal{D} be an open set of \mathbb{R}^n . If the partial derivatives of f exist and are continuous on \mathcal{D} , then f is differentiable on \mathcal{D} .*

Example 1.12. *Given*

$$f(x, y) = \begin{cases} \frac{xy^2}{x^4 + y^2}, & (x, y) \neq (0, 0), \\ 0, & (x, y) = (0, 0). \end{cases}$$

Find the region in which f is differentiable.

2 The Implicit Function Theorem

We start with a simple example. Consider $\mathcal{S} = \{(x, y) \in \mathbb{R}^2 \text{ such that } x^2 + y^2 = 1\}$, which is just the unit circle in the plane. Can we find a function $y = y(x)$ such that $x^2 + y(x)^2 = 1$? Obviously, in this example, we cannot find one function to describe the whole unit circle in this way. However, we can do it locally, that is in a neighbourhood of a point $(a, b) \in \mathcal{S}$, as long as $b \neq 0$. In this example we can find y explicitly: it is $y(x) = \sqrt{1 - x^2}$ if $b > 0$ and $y(x) = -\sqrt{1 - x^2}$ if $b < 0$ both for $|x| < 1$. Notice also, that if $b = 0$, we cannot find such a function y , but we can instead write x as a function of y . The Implicit Function Theorem describes conditions under which certain variables can be written as functions of the others. In \mathbb{R}^2 it can be stated as follows:

Theorem 2.1 (Implicit Function Theorem in \mathbb{R}^2). Let \mathcal{D} be open in \mathbb{R}^2 . Let $f : \mathcal{D} \rightarrow \mathbb{R}$ be *continuously differentiable*. Suppose that there exists a point $(a, b) \in \mathcal{D}$ such that $f(a, b) = 0$ and $\frac{\partial f}{\partial y}(a, b) \neq 0$. Then there exist open interval $I \times J \in \mathcal{D}$ such that :

- (i) For every $x \in I$ the equation $f(x, y) = 0$ has a unique solution in J which defines y as a function $y = \varphi(x)$ in I ;
- (ii) φ in C^1 with derivative

$$\varphi'(x) = -\frac{\frac{\partial f}{\partial x}(x, \varphi(x))}{\frac{\partial f}{\partial y}(x, \varphi(x))}.$$

Example 2.2. Show that the equation $xe^y + y^2 - 1 = 0$ has a unique continuously differentiable solution $y = \varphi(x)$ near the point $(0, 1)$.

Evaluate the derivative of φ at $x = 1$.

Let $f(x, y) = xe^y + y^2 - 1$. Then, note that $f \in C^1(\mathbb{R}^2)$ and $f(0, 1) = 0$. Moreover, we have

$$\frac{\partial f}{\partial x}(x, y) = e^y \quad \text{and} \quad \frac{\partial f}{\partial y}(x, y) = xe^y + 2y.$$

Then, $\frac{\partial f}{\partial y}(0, 1) \neq 0$, so by implicit theorem there exists an implicit function $\varphi : I \rightarrow J$, such that $y = \varphi(x)$ and $1 = \varphi(0)$.

we have

$$\varphi'(x) = -\frac{\frac{\partial f}{\partial x}(x, \varphi(x))}{\frac{\partial f}{\partial y}(x, \varphi(x))} = \frac{e^{\varphi(x)}}{xe^{\varphi(x)} + 2\varphi(x)}.$$

Hence, it results:

$$\varphi'(1) = \frac{e}{2}.$$

Theorem 2.3. Let \mathcal{D} be an open set of \mathbb{R}^{n+m} . Let $f \in C^1(\mathcal{D}, \mathbb{R}^m)$ and $(x_0, y_0) \in \mathcal{D}$ such that $f(x_0, y_0) = 0$. If $D_y f(x_0, y_0)$ is invertible then there exist open neighbourhoods U of x_0 and V of y_0 and a function $\varphi \in C^1(U, V)$ such that

$$\{(x, y) \in U \times V : f(x, y) = 0\} \iff \{(x, y) : x \in U, y = \varphi(x)\}.$$

Furthermore, we have

$$D\varphi(x_0) = -(D_y f(x_0, y_0))^{-1} D_x f(x_0, y_0).$$

Example 2.4. Consider the system of equations

$$\begin{cases} x^3 + y^3 + z^3 - 7 = 0, \\ xy + yz + xz + 2 = 0. \end{cases}$$

Let $f : \mathbb{R}^3 \rightarrow \mathbb{R}^2$ such that $f(x, y, z) = (f_1(x, y, z), f_2(x, y, z))$, where

$$\begin{cases} f_1(x, y, z) = x^3 + y^3 + z^3 - 7, \\ f_2(x, y, z) = xy + yz + xz + 2. \end{cases}$$

Note that $f(2, -1, 0) = (0, 0)$. Set $u = (y, z)$. Then, we have

$$D_u f(x, y, z) = \begin{pmatrix} \frac{\partial f_1}{\partial y}(x, y, z) & \frac{\partial f_1}{\partial z}(x, y, z) \\ \frac{\partial f_2}{\partial y}(x, y, z) & \frac{\partial f_2}{\partial z}(x, y, z) \end{pmatrix} = \begin{pmatrix} 3y^2 & 3z^2 \\ x + z & x + y \end{pmatrix}.$$

Therefore, we have

$$D_u f(2, -1, 0) = \begin{pmatrix} 3 & 0 \\ 2 & 1 \end{pmatrix} \quad \text{and} \quad \det D_{(y,z)} f(2, -1, 0) = 3 \neq 0.$$

Thus, the Implicit Function Theorem implies that there exist open neighbourhoods $U \in \mathbb{R}$ of 2 and $V \in \mathbb{R}^2$ of $(-1, 0)$ and a continuously differentiable function $\varphi(x) : U \rightarrow V$, with $\varphi(2) = (-1, 0)$, such that

$$f(x, y, z) = 0 \iff \varphi(x) = (\varphi_1(x), \varphi_2(x)).$$

for all $x \in U$, $y \in V$. Furthermore, the derivative of φ at $x_0 = 2$ is given by

$$\begin{aligned} \varphi'(2) &= -(D_u f(2, -1, 0))^{-1} D_x f(-2, 1, 0) \\ &= -\begin{pmatrix} 3 & 0 \\ 2 & 1 \end{pmatrix}^{-1} \begin{pmatrix} 12 \\ -1 \end{pmatrix} \\ &= \frac{1}{3} \begin{pmatrix} 1 & 0 \\ -2 & 3 \end{pmatrix} \begin{pmatrix} 12 \\ -1 \end{pmatrix} \\ &= \begin{pmatrix} -4 \\ 9 \end{pmatrix}. \end{aligned}$$

3 Inverse function Theorem

Definition 3.1 (Diffeomorphism). Let $f : U \subseteq \mathbb{R}^n \rightarrow V \subseteq \mathbb{R}^n$, for U and V are open in \mathbb{R}^n . We say that f is a diffeomorphism if and only if is bijective, that is there exists $f^{-1} : V \rightarrow U$, and if $f \in C^1(U, V)$ and $f^{-1} \in C^1(V, U)$.

Theorem 3.2 (Inverse function Theorem). Let $D \subseteq \mathbb{R}^n$ be open, let $f \in C^1(D, \mathbb{R}^n)$ and let $x_0 \in D$. If $Df(x_0)$ is invertible, then there exists an open neighbourhood U of x_0 such that $f(U)$ is open and $f : U \rightarrow f(U)$ is a diffeomorphism. Furthermore, we have

$$Df^{-1}(f(x_0)) = (Df(x_0))^{-1}.$$

Example 3.3. Consider $f : \mathbb{R}^2 \rightarrow \mathbb{R}^2$ given by

$$f(x, y) = (x^2 - 2xy, x + y).$$

Is f locally invertible at the point $(1, -1)$.

Let $f(x, y) = (f_1(x, y), f_2(x, y)) = (x^2 - 2xy, x + y)$. Firstly, note that $f \in \mathcal{C}^1(\mathbb{R}^2)$. Next, we have

$$Df(x, y) = \begin{pmatrix} \frac{\partial f_1}{\partial x}(x, y) & \frac{\partial f_1}{\partial y}(x, y) \\ \frac{\partial f_2}{\partial x}(x, y) & \frac{\partial f_2}{\partial y}(x, y) \end{pmatrix} = \begin{pmatrix} 3x^2 - 2y^2 & -4xy \\ 1 & 1 \end{pmatrix},$$

and

$$Df(1, -1) = \begin{pmatrix} 1 & 4 \\ 1 & 1 \end{pmatrix}.$$

Since $\det Df(1, -1) = -3 \neq 0$, the Jacobian matrix $Df(1, -1)$ is invertible. Moreover, we have

$$(Df(1, -1))^{-1} = \frac{1}{3} \begin{pmatrix} -1 & 4 \\ 1 & -1 \end{pmatrix}.$$

Therefore, f is locally invertible at the point $(1, -1)$.

4 Exercises

Exercise 4.1. *Given*

$$\begin{cases} xy \sin\left(\frac{1}{x^2+y^2}\right), & (x, y) \neq (0, 1), \\ 0, & (x, y) = (0, 1). \end{cases}$$

Prove that f is differentiable at origin.

To claim that f is differentiable at the point $(0, 0)$, we need to apply the Definition 1.7 directly. Therefore, let us evaluate the following limit:

$$\lim_{(x,y) \rightarrow (0,0)} \frac{f(x, y) - f(0, 0) - \frac{\partial f}{\partial x}(0, 0)x - \frac{\partial f}{\partial y}(0, 0)y}{\sqrt{x^2 + y^2}}.$$

To do this, we will firstly calculate the partial derivatives of f at $(0, 0)$. So, the partial derivative of f with respect to x at $(0, 0)$ is given by

$$\frac{\partial f}{\partial x}(0, 0) = \lim_{h \rightarrow 0} \frac{f(h, 0) - \cancel{f(0, 0)}}{h} = \lim_{h \rightarrow 0} \frac{h \cdot 0 \cdot \sin\left(\frac{1}{h^2+0^2}\right)}{h} = \lim_{h \rightarrow 0} \frac{0}{h} = 0.$$

Similarly, the partial derivative of f with respect to y at $(0, 0)$ is expressed as follows:

$$\frac{\partial f}{\partial y}(0, 0) = \lim_{h \rightarrow 0} \frac{f(0, h) - \cancel{f(0, 0)}}{h} = \lim_{h \rightarrow 0} \frac{0 \cdot h \sin\left(\frac{1}{0^2+h^2}\right)}{h} = \lim_{h \rightarrow 0} \frac{0}{h} = 0.$$

Then, we have

$$\lim_{(x,y) \rightarrow (0,0)} \frac{f(x, y) - \cancel{f(0, 0)} - \frac{\partial f}{\partial x}(0, 0)x - \frac{\partial f}{\partial y}(0, 0)y}{\sqrt{x^2 + y^2}} = \lim_{(x,y) \rightarrow (0,0)} \frac{xy}{\sqrt{x^2 + y^2}} \sin\left(\frac{1}{x^2 + y^2}\right).$$

Note that

$$\begin{aligned}
 0 \leq \left| \frac{xy}{\sqrt{x^2 + y^2}} \sin\left(\frac{1}{x^2 + y^2}\right) \right| &\leq \frac{|xy|}{\sqrt{x^2 + y^2}} \\
 &\leq \frac{\sqrt{x^2 + y^2} \sqrt{x^2 + y^2}}{\sqrt{x^2 + y^2}} \\
 &= \sqrt{x^2 + y^2}.
 \end{aligned}$$

where we have used: $|\sin u| \leq 1$, $|x| \leq \sqrt{x^2 + y^2}$ and $|y| \leq \sqrt{x^2 + y^2}$ to get the last step. Next, by passing to the limit as (x, y) approaches $(0, 0)$, we obtain

$$0 \leq \lim_{(x,y) \rightarrow (0,0)} \left| \frac{xy}{\sqrt{x^2 + y^2}} \sin\left(\frac{1}{x^2 + y^2}\right) \right| \leq \lim_{(x,y) \rightarrow (0,0)} \sqrt{x^2 + y^2} = 0$$

This implies that $\lim_{(x,y) \rightarrow (0,0)} \frac{xy}{\sqrt{x^2 + y^2}} \sin\left(\frac{1}{x^2 + y^2}\right) = 0$. Hence, f is differentiable at $(0, 0)$.

Exercise 4.2. Consider $f(x, y)$ defined by

$$f(x, y) = \sqrt{|xy|}.$$

Prove that its partial derivatives at the point $(0, 0)$ exist but f is not differentiable at $(0, 0)$.

The partial derivative of f with respect to x at $(0, 0)$ can be obtained as follows:

$$\frac{\partial f}{\partial x}(0, 0) = \lim_{h \rightarrow 0} \frac{f(h, 0) - f(0, 0)}{h} = \lim_{h \rightarrow 0} \frac{\sqrt{|h \cdot 0|}}{h} = \lim_{h \rightarrow 0} \frac{0}{h} = 0.$$

Similarly, the partial derivative of f with respect to y at $(0, 0)$ is given by

$$\frac{\partial f}{\partial y}(0, 0) = \lim_{h \rightarrow 0} \frac{f(0, h) - f(0, 0)}{h} = \lim_{h \rightarrow 0} \frac{\sqrt{|0 \cdot h|}}{h} = \lim_{h \rightarrow 0} \frac{0}{h} = 0.$$

Therefore, the partial derivatives of f at the point $(0, 0)$ exist.

Now, we move to study the differentiability of f at $(0, 0)$. To this end, we will evaluate the following limit

$$\lim_{(x,y) \rightarrow (0,0)} \frac{f(x, y) - f(0, 0) - \frac{\partial f}{\partial x}(0, 0)x - \frac{\partial f}{\partial y}(0, 0)y}{\sqrt{x^2 + y^2}} = \lim_{(x,y) \rightarrow (0,0)} \frac{\sqrt{|xy|}}{\sqrt{x^2 + y^2}}.$$

Therefore, we can observe that along the line $y = x$, we have

$$\lim_{(x,y) \rightarrow (0,0)} \frac{\sqrt{|xy|}}{\sqrt{x^2 + y^2}} = \lim_{t \rightarrow 0} \frac{\sqrt{t^2}}{\sqrt{2t^2}} = \frac{1}{\sqrt{2}}.$$

On the other hand, going along the x -axis, we obtain

$$\lim_{(x,y) \rightarrow (0,0)} \frac{\sqrt{|xy|}}{\sqrt{x^2 + y^2}} = \lim_{t \rightarrow 0} \frac{\sqrt{t \cdot 0}}{\sqrt{t^2 + 0^2}} = 0.$$

Therefore, $\lim_{(x,y) \rightarrow (0,0)} \frac{\sqrt{|xy|}}{\sqrt{x^2 + y^2}}$ does not exist. This implies that f is not differentiable at $(0, 0)$.

Exercise 4.3. Consider

$$\begin{cases} \frac{x^2(y-1)}{\sqrt{x^2+(y-1)^2}}, & (x, y) \neq (0, 1), \\ 0, & (x, y) = (0, 1). \end{cases}$$

1. Evaluate the partial derivatives of f on all of \mathbb{R}^2 .
2. Is f differentiable?

Solution. 1. For all point $(x, y) \neq (0, 1)$, we have

$$\frac{\partial f}{\partial x}(x, y) = \frac{x(y-1)[x^2 + 2(y-1)^2]}{(x^2 + (y-1)^2)^{\frac{3}{2}}},$$

and

$$\frac{\partial f}{\partial y}(x, y) = \frac{x^4}{(x^2 + (y-1)^2)^{\frac{3}{2}}}.$$

At the point $(x, y) = (0, 1)$, with the help of definition, we can get

$$\frac{\partial f}{\partial x}(0, 1) = \lim_{h \rightarrow 0} \frac{f(h, 1) - \cancel{f(0, 1)}^0}{h} = \lim_{h \rightarrow 0} = \lim_{h \rightarrow 0} \frac{\frac{h^2 \cdot 0}{\sqrt{h^2 + 0^2}}}{h} = \lim_{h \rightarrow 0} \frac{0}{h} = 0,$$

and

$$\frac{\partial f}{\partial y}(0, 1) = \lim_{h \rightarrow 0} \frac{f(0, 1+h) - \cancel{f(0, 1)}^0}{h} = \lim_{h \rightarrow 0} = \lim_{h \rightarrow 0} \frac{\frac{0^2 \cdot h^2}{\sqrt{0^2 + h^2}}}{h} = \lim_{h \rightarrow 0} \frac{0}{h} = 0.$$

Therefore, we can write

$$\frac{\partial f}{\partial x}(x, y) = \begin{cases} \frac{x(y-1)[x^2 + 2(y-1)^2]}{(x^2 + (y-1)^2)^{\frac{3}{2}}}, & (x, y) \neq (0, 1), \\ 0, & (x, y) = (0, 1), \end{cases}$$

and

$$\frac{\partial f}{\partial y}(x, y) = \begin{cases} \frac{x^4}{(x^2 + (y-1)^2)^{\frac{3}{2}}}, & (x, y) \neq (0, 1), \\ 0, & (x, y) = (0, 1). \end{cases}$$

2. Observe that for any $(x, y) \neq (0, 1)$, the partial derivatives $\frac{\partial f}{\partial x}$ and $\frac{\partial f}{\partial y}$ are continuous functions. This is because they are the quotient of continuous functions and their denominators

do not vanish at those points. Thus, f is differentiable for any $(x, y) \neq (0, 1)$.

Next, we move to study the differentiability of f at the point $(0, 1)$. To this end, let us evaluate the following limit:

$$\begin{aligned} \lim_{(h,k) \rightarrow (0,0)} \frac{f(h, k) - f(0, 1) - \frac{\partial f}{\partial x}(0, 1)h - \frac{\partial f}{\partial y}(0, 1)k}{\sqrt{h^2 + y^2}} &= \lim_{(h,k) \rightarrow (0,0)} \frac{f(h, k)}{\sqrt{h^2 + y^2}} \\ &= \lim_{(h,k) \rightarrow (0,0)} \frac{h^2 k}{h^2 + k^2}. \end{aligned}$$

We have

$$0 \leq \left| \frac{h^2 k}{h^2 + k^2} \right| \leq |k| \frac{h^2}{h^2} = |k|,$$

which follows by using $\frac{1}{h^2 + k^2} \leq \frac{1}{h^2}$. Next, by passing to the limit when (h, k) goes to $(0, 1)$, we obtain

$$0 \leq \lim_{(h,k) \rightarrow (0,0)} \left| \frac{h^2 k}{h^2 + k^2} \right| \leq \lim_{(h,k) \rightarrow (0,0)} |k|.$$

Hence, by squeeze principle, it yields $\lim_{(h,k) \rightarrow (0,0)} \frac{h^2 k}{h^2 + k^2} = 0$. Therefore, we conclude that

$$\lim_{(h,k) \rightarrow (0,0)} \frac{f(h, k) - f(0, 1) - \frac{\partial f}{\partial x}(0, 1)h - \frac{\partial f}{\partial y}(0, 1)k}{\sqrt{h^2 + y^2}} = 0,$$

which means that f is differentiable at the point $(0, 1)$. Consequently, we deduce that f is differentiable on all of \mathbb{R}^2 .

Exercise 4.4. Define

$$f(x, y) = \begin{cases} \frac{x \sin y}{x^2 + y^2}, & (x, y) \neq (0, 0), \\ 0, & (x, y) = (0, 0). \end{cases}$$

1. Study the continuity of f on all of \mathbb{R}^2 .
2. Evaluate the partial derivatives of f at the origin.
3. Determine the region in which f is differentiable.

Solution. 1. Observing that $\frac{x \sin y}{x^2 + y^2}$ is continuous everywhere except at the origin because it is written as the quotient of continuous functions and its denominator never vanishes.

Next, we say that f is continuous at the point $(0, 0)$ if $\lim_{(x,y) \rightarrow (0,0)} f(x, y) = f(0, 0) = 0$.

Therefore, passing through the curve $x = y$, we have

$$\lim_{(x,y) \rightarrow (0,0)} f(x, y) = \lim_{t \rightarrow 0} f(t, t) = \lim_{t \rightarrow 0} \frac{t \sin t}{2t^2} = \frac{1}{2} \lim_{t \rightarrow 0} \frac{\sin t}{t} = \frac{1}{2}.$$

On the other hand, by passing through the x -axis, we obtain

$$\lim_{(x,y) \rightarrow (0,0)} f(x, y) = \lim_{t \rightarrow 0} f(t, 0) = \lim_{t \rightarrow 0} \frac{t \sin 0}{t^2 + 0^2} = \lim_{t \rightarrow 0} \frac{0}{t^2} = 0.$$

The two limits do not coincide. Thus, f does not admit a limit at the point $(0, 0)$ and hence f is not continuous at the origin.

2. The partial derivative at $(0, 0)$ with respect to x is given by

$$\frac{\partial f}{\partial x}(0, 0) = \lim_{h \rightarrow 0} \frac{f(h, 0) - \cancel{f(0, 0)}^0}{h} = \lim_{h \rightarrow 0} \frac{h \sin 0}{h^2 + 0^2} = \lim_{h \rightarrow 0} \frac{0}{h} = 0,$$

and the partial derivative at $(0, 0)$ with respect to y is given by

$$\frac{\partial f}{\partial y}(0, 0) = \lim_{h \rightarrow 0} \frac{f(0, h) - \cancel{f(0, 0)}^0}{h} = \lim_{h \rightarrow 0} \frac{0 \cdot \sin h}{0^2 + h^2} = \lim_{h \rightarrow 0} \frac{0}{h^2} = 0.$$

3. Note that $f \in \mathcal{C}^1(\mathbb{R}^2 \setminus \{(0, 0)\})$ because the partial derivatives of f exist and continuous for any $(x, y) \neq (0, 0)$. However, since f is not continuous at the point $(0, 0)$, f is not differentiable at this point. Thus, f is differentiable on $\mathbb{R}^2 \setminus \{(0, 0)\}$.

Exercise 4.5. Given

$$f(x, y) = \begin{cases} xy \ln(x^2 + y^2), & (x, y) \neq (0, 0), \\ 0, & (x, y) = (0, 0). \end{cases}$$

1. Show that f is continuous function on all of \mathbb{R}^2 .
2. Find the partial derivatives of f on all of \mathbb{R}^2 .
3. Study the differentiability of f on \mathbb{R}^2 , and calculate its differential (if it exists).

Solution. 1. The function $f(x, y)$ is continuous on $\mathbb{R}^2 \setminus \{(0, 0)\}$ because f is product of two continuous functions.

Next, we say that f is continuous function at the origin if $\lim_{(x,y) \rightarrow (0,0)} f(x, y) = f(0, 0) = 0$.

To this end, by using the polar coordinate, we can obtain

$$\begin{aligned} \lim_{(x,y) \rightarrow (0,0)} xy \ln(x^2 + y^2) &= \lim_{\substack{r \rightarrow 0 \\ \forall \theta}} r^2 \cos \theta \sin \theta \ln(r^2(\cos^2 \theta + \sin^2 \theta)) \\ &= \lim_{\substack{r \rightarrow 0 \\ \forall \theta}} r^2 \ln(r^2) \sin \theta \cos \theta. \end{aligned}$$

Note that

$$0 \leq |r^2 \ln(r^2) \sin \theta \cos \theta| \leq |r^2 \ln(r^2)|, \quad (\text{since } |\sin \theta \cos \theta| \leq 1).$$

By passing to the limit as r goes to 0, we find

$$0 \leq \lim_{r \rightarrow 0} |r^2 \ln(r^2) \sin \theta \cos \theta| \leq \lim_{r \rightarrow 0} \cancel{|r^2 \ln(r^2)|}^0.$$

Thus, by squeeze principle it yields: $\lim_{r \rightarrow 0} r^2 \ln(r^2) \sin \theta \cos \theta = 0$. Therefore, we have

$$\lim_{(x,y) \rightarrow (0,0)} xy \ln(x^2 + y^2) = f(0, 0) = 0,$$

which means that f is continuous function at the origin. Consequently, it results that f is continuous on all of \mathbb{R}^2 .

2. Firstly, the function f is well-defined for all $(x, y) \neq (0, 0)$, so f admits partial derivatives with respect of x and y . Therefore, we have

$$\frac{\partial f}{\partial x}(x, y) = y \ln(x^2 + y^2) + \frac{2x^2 y}{x^2 + y^2},$$

and

$$\frac{\partial f}{\partial y}(x, y) = x \ln(x^2 + y^2) + \frac{2xy^2}{x^2 + y^2}.$$

Next, the partial derivative of f with respect to x at the origin is given by

$$\frac{\partial f}{\partial x}(0, 0) = \lim_{h \rightarrow 0} \frac{f(h, 0) - \cancel{f(0, 0)}}{h} = \lim_{h \rightarrow 0} \frac{0}{h} = 0.$$

and similarly, the partial derivative of f with respect to y at the origin is

$$\frac{\partial f}{\partial y}(0, 0) = \lim_{h \rightarrow 0} \frac{f(0, h) - \cancel{f(0, 0)}}{h} = \lim_{h \rightarrow 0} \frac{0}{h} = 0.$$

Therefore, we may write

$$\frac{\partial f}{\partial x}(x, y) = \begin{cases} y \ln(x^2 + y^2) + \frac{2x^2 y}{x^2 + y^2}, & (x, y) \neq (0, 0), \\ 0, & (x, y) = (0, 0). \end{cases}$$

and

$$\frac{\partial f}{\partial y}(x, y) = \begin{cases} x \ln(x^2 + y^2) + \frac{2xy^2}{x^2 + y^2}, & (x, y) \neq (0, 0), \\ 0, & (x, y) = (0, 0). \end{cases}$$

3. Note that the partial derivatives $\frac{\partial f}{\partial x}$ and $\frac{\partial f}{\partial y}$ are continuous functions on $\mathbb{R}^2 \setminus \{(0, 0)\}$, which implies that f differentiable on $\mathbb{R}^2 \setminus \{(0, 0)\}$, and hence, we have

$$\begin{aligned} d_{(x,y)}f(h, k) &= \frac{\partial f}{\partial x}(x, y)h + \frac{\partial f}{\partial y}(x, y)k \\ &= \left[y \ln(x^2 + y^2) + \frac{2x^2 y}{x^2 + y^2} \right] h + \left[x \ln(x^2 + y^2) + \frac{2xy^2}{x^2 + y^2} \right] k. \end{aligned}$$

To investigate the differentiability of f at the point $(0, 0)$, we will study the following limit:

$$\begin{aligned} \lim_{(x,y) \rightarrow (0,0)} \frac{f(x, y) - \cancel{f(0, 0)} - \frac{\partial f}{\partial x}(0, 0)x - \frac{\partial f}{\partial y}(0, 0)y}{\sqrt{x^2 + y^2}} &= \lim_{(x,y) \rightarrow (0,0)} \frac{f(x, y)}{\sqrt{x^2 + y^2}} \\ &= \lim_{(x,y) \rightarrow (0,0)} \frac{xy \ln(x^2 + y^2)}{\sqrt{x^2 + y^2}}. \end{aligned}$$

By using polar coordinates, we obtain

$$\begin{aligned} \lim_{(x,y) \rightarrow (0,0)} \frac{xy \ln(x^2 + y^2)}{\sqrt{x^2 + y^2}} &= \lim_{\substack{r \rightarrow 0 \\ \forall \theta}} \frac{r^2 \cos \theta \sin \theta \ln(r^2)}{\sqrt{r^2(\cos^2 \theta + \sin^2 \theta)}} \\ &= \lim_{\substack{r \rightarrow 0 \\ \forall \theta}} 2 \cos \theta \sin \theta \cdot r \ln r \\ &= 0, \end{aligned}$$

which follows from $0 \leq |2 \cos \theta \sin \theta \cdot r \ln r| \leq 2|r \ln r|$ and $\lim_{r \rightarrow 0} r \ln r = 0$. Therefore, the function f is differentiable at the origin, and thus

$$d_{(0,0)}f(h, k) = \frac{\partial f}{\partial x}(0, 0)h + \frac{\partial f}{\partial y}(0, 0)k = 0.$$

Exercise 4.6. Consider $f(x, y)$ defined by

$$f(x, y) = \begin{cases} \frac{x^2(x-y)}{x^2+y^2}, & (x, y) \neq (0, 0), \\ 0, & (x, y) = (0, 0). \end{cases}$$

1. Discuss the continuity of f at origin.
2. Evaluate the partial derivatives of f on all of \mathbb{R}^2 .
3. Study the continuity of the partial derivatives at origin.
4. Evaluate the directional derivative of f at the point $(0, 0)$.
5. Is f differentiable at the point $(0, 0)$.

1. We have

$$\lim_{(x,y) \rightarrow (0,0)} f(x, y) = \lim_{(x,y) \rightarrow (0,0)} \frac{x^2(x-y)}{x^2+y^2}.$$

Note that

$$0 \leq \left| \frac{x^2(x-y)}{x^2+y^2} \right| \leq \frac{x^2+y^2}{x^2+y^2} |x-y|.$$

By passing to the limit as (x, y) approaches $(0, 0)$, we find

$$0 \leq \lim_{(x,y) \rightarrow (0,0)} \left| \frac{x^2(x-y)}{x^2+y^2} \right| \leq \lim_{(x,y) \rightarrow (0,0)} |x-y| \xrightarrow{0} 0.$$

Thus, it follows from squeezeprinciple that: $\lim_{(x,y) \rightarrow (0,0)} \frac{x^2(x-y)}{x^2+y^2} = 0$, which means that

$\lim_{(x,y) \rightarrow (0,0)} f(x, y) = f(0, 0) = 0$, and hence f is continuous function at the point $(0, 0)$.

2. For all point $(x, y) \neq (0, 0)$, we have

$$\frac{\partial f}{\partial x}(x, y) = \frac{x(x^3 + 3xy - 2y^3)}{(x^2 + y^2)^2},$$

and

$$\frac{\partial f}{\partial y}(x, y) = \frac{2x^2(y-x)}{(x^2+y^2)^2} - \frac{x^2}{x^2+y^2}.$$

Next, the partial derivative of f with respect to x at $(0, 0)$ is given by

$$\frac{\partial f}{\partial x}(0, 0) = \lim_{h \rightarrow 0} \frac{f(h, 0) - f(0, 0)}{h} \xrightarrow{0} = \lim_{h \rightarrow 0} \frac{\frac{h^2(h-0)}{h^2+0^2}}{h} = \lim_{h \rightarrow 0} \frac{h}{h} = 1.$$

Similarly, the partial derivative of f with respect to y at $(0, 0)$ can be obtained as follows

$$\frac{\partial f}{\partial y}(0, 0) = \lim_{h \rightarrow 0} \frac{f(0, h) - \cancel{f(0, 0)}}{h} = \lim_{h \rightarrow 0} \frac{0^2 \cdot (0-h)}{0^2+h^2} = \lim_{h \rightarrow 0} \frac{0}{h} = 0.$$

Therefore, we can obtain

$$\frac{\partial f}{\partial x}(x, y) = \begin{cases} \frac{x(x^3+3xy-2y^3)}{(x^2+y^2)^2}, & (x, y) \neq (0, 0), \\ 1, & (x, y) = (0, 0), \end{cases}$$

and

$$\frac{\partial f}{\partial y}(x, y) = \begin{cases} \frac{2x^2(y-x)}{(x^2+y^2)^2} - \frac{x^2}{x^2+y^2}, & (x, y) \neq (0, 0), \\ 0, & (x, y) = (0, 0). \end{cases}$$

3. First, in order to study the continuity of $\frac{\partial f}{\partial x}(x, y)$ at $(0, 0)$, we need to evaluate the following limit:

$$\lim_{(x,y) \rightarrow (0,0)} \frac{\partial f}{\partial x}(x, y) = \lim_{(x,y) \rightarrow (0,0)} \frac{x(x^3 + 3xy - 2y^3)}{(x^2 + y^2)^2}.$$

Therefore, by approaching the limit along the x -axis, we find

$$\begin{aligned} \lim_{(x,y) \rightarrow (0,0)} \frac{\partial f}{\partial x}(x, y) &= \lim_{t \rightarrow 0} \frac{\partial f}{\partial x}(t, 0) \\ &= \lim_{t \rightarrow 0} \frac{t^4}{t^4} = 1. \end{aligned}$$

On the other hand, by approaching the limit this time along the y -axis, we obtain

$$\begin{aligned} \lim_{(x,y) \rightarrow (0,0)} \frac{\partial f}{\partial x}(x, y) &= \lim_{t \rightarrow 0} \frac{\partial f}{\partial x}(0, t) \\ &= \lim_{t \rightarrow 0} \frac{0}{t^4} = 0. \end{aligned}$$

Obviously ($1 \neq 0$), then $\frac{\partial f}{\partial x}$ does not admit a limit at $(0, 0)$, and hence, $\frac{\partial f}{\partial x}$ is not continuous at $(0, 0)$.

In the same manne as before, to investigate the continuity of $\frac{\partial f}{\partial y}$ at the origin, we will firstly evaluate the following limit:

$$\lim_{(x,y) \rightarrow (0,0)} \frac{\partial f}{\partial y}(x, y) = \lim_{(x,y) \rightarrow (0,0)} \left[\frac{2x^2(y-x)}{(x^2+y^2)^2} - \frac{x^2}{x^2+y^2} \right].$$

We can observe that along the the line $y = x$, we have

$$\begin{aligned} \lim_{(x,y) \rightarrow (0,0)} \frac{\partial f}{\partial y}(x, y) &= \lim_{t \rightarrow 0} \frac{\partial f}{\partial y}(t, t) \\ &= \lim_{t \rightarrow 0} \left[\frac{0}{(2t^2)^2} - \frac{t^2}{2t^2} \right] = -\frac{1}{2}. \end{aligned}$$

Next, if we approach the limit along y -axis, it yields

$$\begin{aligned} \lim_{(x,y) \rightarrow (0,0)} \frac{\partial f}{\partial y}(x, y) &= \lim_{t \rightarrow 0} \frac{\partial f}{\partial y}(0, t) \\ &= \lim_{t \rightarrow 0} \left[\frac{0}{t^4} - \frac{0}{t^2} \right] = 0. \end{aligned}$$

Note that the two limits do not coincide. This implies that $\frac{\partial f}{\partial y}$ does not have a limit at $(0, 0)$. Therefore, $\frac{\partial f}{\partial y}$ is not continuous at the origin.

4. The directional derivative of f at the point $(0, 0)$ in the direction of $v = (h_1, h_2)$ is given by

$$\begin{aligned} D_v f(0, 0) &= \lim_{t \rightarrow 0} \frac{f(t + h_1, t + h_2) - f(0, 0)}{t} \\ &= \lim_{t \rightarrow 0} \frac{t^2 h_1^2 (t(h_1 - h_2))}{t(t^2 h_1^2 + t^2 h_2^2)} \\ &= \frac{h_1^2 (h_1 - h_2)}{h_1^2 + h_2^2}. \end{aligned}$$

Note that, if $v = (1, 0)$, then $D_{(1,0)} f(0, 0) = \frac{\partial f}{\partial x}(0, 0) = 1$; and if $v = (0, 1)$, we have $D_{(0,1)} f(0, 0) = \frac{\partial f}{\partial y}(0, 0) = 0$.

5. To check the differentiability of f , we need to show that

$$\lim_{(x,y) \rightarrow (0,0)} \frac{f(x, y) - f(0, 0) - \frac{\partial f}{\partial x}(0, 0)x - \frac{\partial f}{\partial y}(0, 0)y}{\sqrt{x^2 + y^2}} = 0.$$

Therefore, we have

$$\lim_{(x,y) \rightarrow (0,0)} \frac{\frac{x^2(x-y)}{x^2+y^2} - x}{\sqrt{x^2 + y^2}} = \lim_{(x,y) \rightarrow (0,0)} \frac{xy(x+y)}{(x^2 + y^2)^{\frac{3}{2}}}.$$

We can see easily that the limit along the path $y = x$ is given by

$$\lim_{(x,y) \rightarrow (0,0)} \frac{xy(x+y)}{(x^2 + y^2)^{\frac{3}{2}}} = \lim_{t \rightarrow 0} \frac{t^3}{2t^3} = \frac{1}{2}.$$

This means that f is not differentiable at the point $(0, 0)$.

In this exercise, we have seen that f is continuous at $(0, 0)$ and all directional derivatives of f at $(0, 0)$ exist, but f is not differentiable at $(0, 0)$.

Exercise 4.7. Let $f : \mathbb{R}^2 \rightarrow \mathbb{R}$ given by

$$f(x, y) = \begin{cases} \frac{x^3 - y^2}{x^2 + y^2}, & (x, y) \neq (0, 0), \\ 0, & (x, y) = (0, 0). \end{cases}$$

1. Evaluate the partial derivatives of f at the origin.
2. Is f differentiable at the point $(0, 0)$?
3. Is f of class C^1 function at $(0, 0)$?

Exercise 4.8. 1. Show that the equation

$$\ln x + e^{\frac{y}{x}} = 1$$

defined in the neighborhood of the point $(1, 0)$ can be expressed as an implicit function $y = \varphi(x)$ such that $\varphi(1) = 0$.

2. Write the equation of the tangent to the curve $y = \varphi(x)$ at 1.

Solution. Notice that the function: $f(x, y) = \ln x + e^{\frac{y}{x}} - 1$ is defined on $D_f = \mathbb{R}_+ \setminus \{0\} \times \mathbb{R}$. Then, f is of class $\mathcal{C}^1(D_f)$ function. Therefore, for any $(x, y) \in D_f$, we have

$$\frac{\partial f}{\partial y}(x, y) = \frac{e^{\frac{y}{x}}}{x}.$$

Therefore, we have $\frac{\partial f}{\partial y}(1, 0) = 1 \neq 0$ and $f(1, 0) = 0$. Hence, by implicit function Theorem, there exists an open interval I containing 1 and a unique function $\varphi : I \rightarrow \mathbb{R}$ of class $\mathcal{C}^1(I)$ such that $\varphi(1) = 0$ and $f(x, \varphi(x)) = 0$.

2. The derivative of φ with respect to x is given by

$$\varphi'(x) = -\frac{\frac{\partial f}{\partial x}(x, y)}{\frac{\partial f}{\partial y}(x, y)} = e^{-\frac{\varphi(x)}{x}}.$$

So $\varphi(1) = 0$. Hence, the equation of the tangent to the curve $y = \varphi(x)$ at $x = 1$ is given as

$$\begin{aligned} y &= \varphi(1) + \varphi'(1)(x - 1) \\ &= 0 + (-1)(x - 1) \\ &= 1 - x. \end{aligned}$$

Exercise 4.9. Consider the function $f : \mathbb{R}^3 \rightarrow \mathbb{R}$ given by

$$f(x, y, z) = x^5 + xyz + y^3 + 3xz^4 - 2$$

1. Show that the equation $f(x, y, z) = 0$ is defined in the neighborhood of the point $(1, -1)$ is an implicit function $z = \varphi(x, y)$ such that $\varphi(1, -1) = 1$.

2. Give the equation of the plane tangent to the surface $z = \varphi(x, y)$ at the point $(1, 1)$.

Solution. 1. The function f is of class $\mathcal{C}^1(\mathbb{R}^3)$. Therefore, we have

$$\frac{\partial f}{\partial z}(x, y, z) = xy + 12xz^3.$$

Hence, it follows $\frac{\partial f}{\partial z}(1, -1, 1) = 0$, and $f(1, -1, 1) = 0$. Then, by the implicit function Theorem, there is an open set U of \mathbb{R}^2 containing $(1, -1)$ and a unique function $\varphi(x, y) : U \rightarrow \mathbb{R}$ of class \mathcal{C}^1 such that $\varphi(1, -1) = 1$ and $f(x, y, \varphi(x, y)) = 0$.

2. The equation of the tangent plane of the surface $z = \varphi(x, y)$ at the point $(1, -1)$ is given as

$$z = \varphi(1, -1) + \frac{\partial \varphi}{\partial x}(1, -1)(x - 1) + \frac{\partial \varphi}{\partial y}(1, -1)(y + 1).$$

Observe that:

$$\begin{aligned} \frac{\partial \varphi}{\partial x}(x, y) &= -\frac{\frac{\partial f}{\partial x}(x, y, z)}{\frac{\partial f}{\partial z}(x, y, z)} \\ &= \frac{5x^4 + y\varphi(x, y) + 3\varphi^4(x, y)}{xy + 12\varphi^3(x, y)}. \end{aligned}$$

Thus, it follows that: $\frac{\partial \varphi}{\partial x}(1, -1) = -\frac{7}{11}$. Furthermore, we have

$$\begin{aligned} \frac{\partial \varphi}{\partial y}(x, y) &= -\frac{\frac{\partial f}{\partial y}(x, y, z)}{\frac{\partial f}{\partial z}(x, y, z)} \\ &= \frac{x\varphi(x, y) + 3y^2}{xy + 12\varphi^3(x, y)}. \end{aligned}$$

Hence, we have $\frac{\partial \varphi}{\partial y}(1, -1) = -\frac{4}{11}$. Therefore, we find

$$\begin{aligned} z &= \varphi(1, -1) + \frac{\partial \varphi}{\partial x}(1, -1)(x - 1) + \frac{\partial \varphi}{\partial y}(1, -1)(y + 1) \\ &= \frac{14}{11} - \frac{x}{11} + \frac{4}{11}. \end{aligned}$$

Exercise 4.10. 1. Show that the equation

$$x^4 + 4xy + z^2 - 3yz^2 - 3 = 0.$$

allows to express z as a function of $\varphi(x, y)$ in the neighborhood of $(1, 1, 1)$.

2. Evaluate $\frac{\partial \varphi}{\partial x}(1, 1)$ and $\frac{\partial \varphi}{\partial y}(1, 1)$.

Solution. Note that the function $f(x, y, z) = x^4 + 4xy + z^2 - 3yz^2 - 3$ is of class \mathcal{C}^1 on \mathbb{R}^2 . Then, we have

$$\frac{\partial f}{\partial z}(x, y, z) = 2z - 6yz,$$

and at the point $(1, 1)$, it follows that $\frac{\partial f}{\partial z}(1, 1, 1) = -4 \neq 0$. Since $f(1, 1, 1) = 0$ and $\frac{\partial f}{\partial z}(1, 1, 1) \neq 0$, the implicit function Theorem implies that there exist an open set \mathbf{U} of \mathbb{R}^2 containing $(1, 1)$, and a unique function $\varphi(x, y) : \mathbf{U} \rightarrow \mathbb{R}$ of class \mathcal{C}^1 such that $\varphi(1, 1) = 1$ and $f(x, y, \varphi(x, y)) = 0$.

2. We have

$$\frac{\partial \varphi}{\partial x}(x, y) = -\frac{\frac{\partial f}{\partial x}(x, y, z)}{\frac{\partial f}{\partial z}(x, y, z)} = -\frac{3x^3 + 4y}{(2 - 6y)\varphi(x, y)}.$$

Hence, we get

$$\frac{\partial \varphi}{\partial z}(1, 1) = \frac{7}{4}.$$

Moreover, we have

$$\frac{\partial \varphi}{\partial y}(x, y) = -\frac{\frac{\partial f}{\partial y}(x, y, z)}{\frac{\partial f}{\partial z}(x, y, z)} = -\frac{4x - 3\varphi^2(x, y)}{(2 - 6y)\varphi(x, y)}.$$

Hence, we get

$$\frac{\partial \varphi}{\partial z}(1, 1) = \frac{1}{4}.$$

Exercise 4.11. 1. Show that the equation:

$$\cos(x2 + y) + \sin(x + y) + e^{x^3y} = 2$$

defined in the neighborhood of the point 0 is an implicit function $y = \varphi(x)$ such that $\varphi(0) = \frac{\pi}{2}$.

2. Show that the function φ has a local maximum at the point 0.

Exercise 4.12. Consider the following system of two equations:

$$\begin{cases} x^2 + 2y^2 + u^2 + v^2 = 6, \\ 2x^3 + 4y^2 + u + v^2 = 9, \end{cases}$$

1. Show that near the point $x_0 = (1, -1, -1, 2)$, (u, v) can be expressed as differentiable function of (x, y) .

2. Compute $\frac{\partial u}{\partial x}$ and $\frac{\partial v}{\partial x}$ at the point $(1, -1)$.

Define $f : \mathbb{R}^4 \rightarrow \mathbb{R}^2$ to be $f(x, y, u, v) = (f_1(x, y, u, v), f_2(x, y, u, v))$, such that

$$f_1(x, y, u, v) = x^2 + 2y^2 + u^2 + v^2 - 6, \quad \text{and} \quad f_2(x, y, u, v) = 2x^3 + 4y^2 + u + v^2 - 9.$$

It is clear that f is of class \mathcal{C}^1 on \mathbb{R}^4 . Moreover, we have

$$D_{(u,v)}f(x, y, u, v) = \det \begin{pmatrix} \frac{\partial f_1}{\partial u} & \frac{\partial f_1}{\partial v} \\ \frac{\partial f_2}{\partial u} & \frac{\partial f_2}{\partial v} \end{pmatrix} \Big|_{x_0} = \det \begin{pmatrix} 2u & 1 \\ 1 & 2v \end{pmatrix} \Big|_{x_0} = -9 \neq 0.$$

Since $f(1, -1, -1, 2) = 0$ and $D_{(u,v)}f(1, -1, -1, 2) \neq 0$, by implicit function Theorem there exist an open set U of \mathbb{R}^2 and a unique function $\varphi(x, y) : U \rightarrow \mathbb{R}^2$, $\varphi(x, y) = (\varphi_1(x, y), \varphi_2(x, y))$, of class \mathcal{C}^1 such that $\varphi(1, -1) = (-1, 2)$ and $f(x, y, \varphi_1(x, y), \varphi_2(x, y)) = 0$.

2. In order to find $\frac{\partial u}{\partial x}$, and $\frac{\partial v}{\partial x}$, we will differentiate both sides of each equation with respect to x , then we obtain

$$\begin{cases} 2x + 2u\frac{\partial u}{\partial x} + 2v\frac{\partial v}{\partial x} = 0, \\ 6x^2 + \frac{\partial u}{\partial x} + 2v\frac{\partial v}{\partial x} = 0 \end{cases}$$

Therefore, by applying Cramer's method, we can find

$$\frac{\partial u}{\partial x} = \frac{\begin{vmatrix} -2x & 1 \\ -6x^2 & 2v \end{vmatrix}}{\begin{vmatrix} 2u & 1 \\ 1 & 2v \end{vmatrix}} = \frac{6x^2 - 4xv}{4uv - 1},$$

and hence, we have $\frac{\partial u}{\partial x}(1, -1) = \frac{2}{9}$. Similarly, it follows

$$\frac{\partial v}{\partial x} = \frac{\begin{vmatrix} 2u & -2x \\ 1 & -6x^2 \end{vmatrix}}{\begin{vmatrix} 2u & 1 \\ 1 & 2v \end{vmatrix}} = \frac{2x - 12x^2u}{4uv - 1},$$

and hence, we have $\frac{\partial v}{\partial x}(1, -1) = \frac{2}{9}$.

Exercise 4.13. Consider the system of equations:

$$\begin{cases} x^3 + y_1^3 + y_2^3 = 7, \\ xy_1 + xy_2 + y_1y_2 = -2, \end{cases}$$

1. Demonstrate that near the point $x_0 = (2, -1, 0)$, we can write (y_1, y_2) as a continuously differentiable function of x , $\varphi(x) = (\varphi_1(x), \varphi_2(x))$.
2. Calculate $y_1'(x)$ and $y_2'(x)$ at the point $(2, -1, 0)$.

Solution. Define $f(x, y_1, y_2) = (f_1(x, y_1, y_2), f_2(x, y_1, y_2))$ such that

$$f_1(x, y_1, y_2) = x^3 + y_1^3 + y_2^3 - 7, \quad \text{and} \quad f_2(x, y_1, y_2) = xy_1 + xy_2 + y_1y_2 + 2.$$

Obviously, f is of class \mathcal{C}^1 on \mathbb{R}^3 . Therefore, it yields

$$D_{(y_1, y_2)}f(x, y_1, y_2) = \det \begin{pmatrix} \frac{\partial f_1}{\partial y_1} & \frac{\partial f_1}{\partial y_2} \\ \frac{\partial f_2}{\partial y_1} & \frac{\partial f_2}{\partial y_2} \end{pmatrix} = \det \begin{pmatrix} 3y_1^2 & 3y_2^2 \\ x + y_2 & x + y_1 \end{pmatrix}.$$

Thus, we obtain

$$D_{(y_1, y_2)}f(2, -1, 0) = \det \begin{pmatrix} 3 & 0 \\ 2 & 1 \end{pmatrix} = 3 \neq 0.$$

Observe that $f(2, -1, 0) = 0$ and $D_{(y_1, y_2)}f(2, -1, 0) \neq 0$, then implicate function Theorem implies that there exist an open neighbourhood $I \subseteq \mathbb{R}$ and continuously differentiable function $\varphi : I \rightarrow \mathbb{R}^2$, $\varphi(x) = (\varphi_1(x), \varphi_2(x))$ such that $\varphi(-1, 0) = 2$ and $f(x, \varphi_1(x), \varphi_2(x)) = 0$.

2. By differentiating both sides of each equation with respect to x , we get

$$\begin{cases} 3x^2 + 3y_1^2 \frac{dy_1}{dx} + 3y_2^2 \frac{dy_2}{dx} = 0, \\ (x + y_2) \frac{dy_1}{dx} + (x + y_1) \frac{dy_2}{dx} + y_1 + y_2 = 0. \end{cases}$$

By employing the Cramer rule, we can get

$$\frac{dy_1}{dx} = \frac{\begin{vmatrix} -3x^2 & 3y_2^2 \\ -y_1 - y_2 & x + y_1 \end{vmatrix}}{\begin{vmatrix} 3y_1^2 & 3y_2 \\ x + y_2 & x + y_1 \end{vmatrix}} = \frac{-x^3 - x^2y_1 + y_1y_2^2 + y_2^3}{(x + y_1)y_1^2 - (x + y_2)y_2^2}.$$

Thus, $y_1'(2) = -\frac{4}{3}$. Similarly, by using the Cramer rule again, we find

$$\frac{dy_2}{dx} = \frac{\begin{vmatrix} 3y_1^2 & -3x^2 \\ x + y_2 & -y_1 - y_2 \end{vmatrix}}{\begin{vmatrix} 3y_1^2 & 3y_2 \\ x + y_2 & x + y_1 \end{vmatrix}} = \frac{x^3 + x^2y_2 - y_1^2y_2 + y_1^3}{(x + y_1)y_1^2 - (x + y_2)y_2^2}.$$

and hence, we have $y_2'(2) = 3$

Exercise 4.14. Verify that the system of equations:

$$\begin{cases} 3x^2 + 2y^2 - 3xy + 4uv = 6, \\ y^2 + v^2 - xv + yu = 0 \end{cases}$$

can be expressed as function of (u, v) (i.e., $x = \varphi_1(u, v)$ and $y = \varphi_2(u, v)$) near the point $(1, 1, 1, 1)$, and compute

$$\frac{\partial^2 x}{\partial u \partial v}(1, 1, 1, 1).$$

Exercise 4.15. Given that $f(x, y, z) = 0$, where f has continuous non-zero first-order partial derivatives in \mathbb{R}^3 .

Show that

$$\frac{\partial x}{\partial y} \frac{\partial y}{\partial z} \frac{\partial z}{\partial x} = -1.$$

Chapter 6

Extrema

1 Local extrema

Definition 1.1. Let $f : \mathcal{D} \subseteq \mathbb{R}^n \rightarrow \mathbb{R}$, for \mathcal{D} open. We say

- (i) f has a local minimum at $x_0 \in \mathcal{D}$ if there exists a neighborhood $\mathcal{U}(x_0) \subset \mathcal{D}$ such that $f(x) \geq f(x_0)$, for every $x \in \mathcal{U}$,
- (ii) f has a local maximum at $x_0 \in \mathcal{D}$ if there exists a neighborhood $\mathcal{U}(x_0) \subset \mathcal{D}$ such that $f(x) \leq f(x_0)$, for every $x \in \mathcal{U}$.

Remark 1.2. (i) Minimal and maximal value are also called extremum value.

(ii) If $\mathcal{U} = \mathcal{D}$, then the local minimum (maximum) of f is global.

Moreover, we have the following important result when f is \mathcal{C}^1 function.

Theorem 1.3 (Necessary condition for a local extremum). Let $f : \mathcal{D} \subseteq \mathbb{R}^n \rightarrow \mathbb{R}$, for \mathcal{D} open, be a \mathcal{C}^1 function. If f has a local extremum at $x_0 \in \mathcal{D}$, then $\nabla f(x_0) = \mathbf{0}_{\mathbb{R}^n}$.

Definition 1.4. Let $f : \mathcal{D} \subseteq \mathbb{R}^n \rightarrow \mathbb{R}$, where \mathcal{D} is open. We say that *interior point* $x_0 \in \mathcal{D}$ is a critical point of f if either

- (i) $\nabla f(x_0) = \mathbf{0}_{\mathbb{R}^n}$, or
- (ii) $\nabla f(x_0)$ is undefined (i.e., the gradient does not exist at x_0).

Example 1.5. Find the critical point of the function

$$f(x, y) = 2x^3 - 3x^2y - 12x^2 - 3y^2.$$

To find the critical point of the function $f : \mathbb{R}^2 \rightarrow \mathbb{R}$, we need to solve $\nabla f(x, y) = \mathbf{0}_{\mathbb{R}^2}$. Therefore, we have

$$\nabla f(x, y) = \begin{pmatrix} x(x - y - 4x) \\ x^2 + 2y \end{pmatrix} = \begin{pmatrix} 0 \\ 0 \end{pmatrix}.$$

Thus, we have the following system

$$\begin{cases} x(x - y - 4) = 0, \\ x^2 + 2y = 0. \end{cases}$$

So, when $x = 0$ we find that $y = 0$ from the second equation of system (1). Next, when $x - y - 4 = 0$, then we deal with the following system

$$\begin{cases} x - y - 4 = 0, \\ x^2 + 2y = 0, \end{cases}$$

By substituting $x = y + 4$ in the second equation of system (1), we find $x^2 + 2x - 8 = 0$, and hence $x = 2$ or $x = -4$ which implies that $y = -2$ or $y = -8$. Therefore, f has three critical points,

$$(0, 0), (2, -2), (-4, -8).$$

Definition 1.6. Let $f : \mathcal{D} \subseteq \mathbb{R}^n \rightarrow \mathbb{R}$, for \mathcal{D} open. A saddle point of f is a critical point at which the function f does not achieve a local extremum value.

Theorem 1.7. Let $f : \mathcal{D} \subseteq \mathbb{R}^2 \rightarrow \mathbb{R}$, for \mathcal{D} open, be \mathcal{C}^2 function. Let x_0 be a critical point of f . Let $P(\lambda)$ be the characteristic polynomial of the Hessian matrix of f at the point x_0 . Let $\lambda_i, i = 1, 2$ the roots of $P_2(\lambda)$. Then, we have

- (i) If the roots are strictly positives, $\lambda_i > 0$, then f has a local minimum at x_0 .
- (ii) If the roots are strictly negatives, $\lambda_i < 0$, then f has a local maximum at x_0 .
- (iii) If the roots do not vanish but have different signs, then f has neither a local minimum nor a local maximum at x_0 (Here, we say that x_0 is saddle point).
- (iv) If at least one of the roots vanishes, then f may have a local minimum, a local maximum, or none of the above (the second-derivative test is inconclusive).

Example 1.8. Find all critical points of the function

$$f(x, y) = \frac{1}{3}x^3 + xy^2 - x^2 - y^2.$$

and determine whether f has a local minimum, maximum, or saddle at them.

Note that f is a polynomial, and hence $f \in \mathcal{C}^1(\mathbb{R}^2)$ (i.e., its partial derivatives are continuous on \mathbb{R}^2). Therefore, to find the critical points of f , we will solve the following system

$$\nabla f(x, y) = 0 \iff \begin{cases} \frac{\partial f}{\partial x}(x, y) = x^2 + y^2 - 2x = 0, \\ \frac{\partial f}{\partial y}(x, y) = 2xy - 2y = 0. \end{cases} \quad (6.1)$$

Therefore, the system (6.1) is equivalent to

$$\begin{cases} x^2 + y^2 - 2x = 0, \\ x = 1, \end{cases} \quad \text{or} \quad \begin{cases} x^2 + y^2 - 2x = 0, \\ y = 0. \end{cases}$$

We can easily observe that the solutions of the first system are $\{(1, 1), (1, -1)\}$, and the solutions of the second system are $\{(0, 0), (2, 0)\}$. Hence, f has four critical points.

Next, the second-derivative test can be applied because $f \in \mathcal{C}^2(\mathbb{R}^2)$ (i.e., the second partial derivatives of f are continuous on \mathbb{R}^2). That is

$$\frac{\partial^2 f}{\partial x^2}(x, y) = 2x - 2, \quad \frac{\partial^2 f}{\partial y^2}(x, y) = 2x - 2, \quad \text{and} \quad \frac{\partial f}{\partial x \partial y}(x, y) = \frac{\partial f}{\partial y \partial x}(x, y) = 2y.$$

- Critical points $(1, \pm 1)$. The Hessian matrix of f at $(1, \pm 1)$ is given by

$$H_{ess}f(1, \pm 1) = \begin{pmatrix} \frac{\partial^2 f}{\partial x^2}(1, \pm 1) & \frac{\partial f}{\partial x \partial y}(1, \pm 1) \\ \frac{\partial f}{\partial y \partial x}(1, \pm 1) & \frac{\partial^2 f}{\partial y^2}(1, \pm 1) \end{pmatrix} = \begin{pmatrix} 0 & 2 \\ 2 & 0 \end{pmatrix}.$$

Then, the characteristic equation of $H_{ess}f(1, \pm 1)$ reads

$$P_2(\lambda) = \det \begin{pmatrix} -\lambda & 2 \\ 2 & -\lambda \end{pmatrix} = \lambda^2 - 4 = 0$$

The roots of $P_2(\lambda) = 0$ are $\lambda_1 = -2$ and $\lambda_2 = 2$, they do not vanish and have opposite signs. Therefore, $(1, \pm 1)$ are saddle points.

- Critical point $(2, 0)$. The Hessian matrix of f at the point $(2, 0)$ reads

$$H_{ess}f(2, 0) = \begin{pmatrix} \frac{\partial^2 f}{\partial x^2}(2, 0) & \frac{\partial f}{\partial x \partial y}(2, 0) \\ \frac{\partial f}{\partial y \partial x}(2, 0) & \frac{\partial^2 f}{\partial y^2}(2, 0) \end{pmatrix} = \begin{pmatrix} 2 & 0 \\ 0 & 2 \end{pmatrix}.$$

Next, the characteristic equation of $H_{ess}f(2, 0)$ is given by

$$P_2(\lambda) = \det \begin{pmatrix} 2 - \lambda & 0 \\ 0 & 2 - \lambda \end{pmatrix} = (2 - \lambda)^2 = 0.$$

Hence, the characteristic equation $P_2(\lambda)$ has one positive root of multiplicity 2, $\lambda_1 = \lambda_2 = 2$. Therefore, the function f has a local minimum at the point $(2, 0)$.

- Critical point $(0, 0)$. The Hessian matrix of f at this point reads

$$H_{ess}f(0, 0) = \begin{pmatrix} \frac{\partial^2 f}{\partial x^2}(0, 0) & \frac{\partial f}{\partial x \partial y}(0, 0) \\ \frac{\partial f}{\partial y \partial x}(0, 0) & \frac{\partial^2 f}{\partial y^2}(0, 0) \end{pmatrix} = \begin{pmatrix} -2 & 0 \\ 0 & -2 \end{pmatrix}.$$

Then, the characteristic equation of $H_{ess}f(0, 0)$ can be expressed as

$$P_2(\lambda) = \det \begin{pmatrix} -2 - \lambda & 0 \\ 0 & -2 - \lambda \end{pmatrix} = (-2 - \lambda)^2 = 0.$$

Thus, the equation $P_2(\lambda) = 0$ has one positive root of multiplicity 2, $\lambda_1 = \lambda_2 = -2$. Hence, f has a local maximum at the critical point $(0, 0)$.

Corollary 1.9. Let f be satisfy the hypotheses of Theorem 1.7. Denote $\mathbf{D} = ab - c^2$, where

$$a = \frac{\partial^2 f}{\partial x^2}(x_0), \quad b = \frac{\partial^2 f}{\partial y^2}(x_0), \quad \text{and} \quad c = \frac{\partial^2 f}{\partial x \partial y}(x_0)$$

Then, we have

- (i) If $\mathbf{D} > 0$ and $a > 0$, then f has a local minimum at x_0 ,
- (ii) If $\mathbf{D} > 0$ and $a < 0$, then f has a local maximum at x_0 ,
- (iii) If $\mathbf{D} < 0$, then x_0 is saddle point of f ,
- (iv) If $\mathbf{D} = 0$, then the second derivatives test does not give any information about the nature of the critical point x_0 .

Example 1.10. Consider f defined by

$$f(x, y) = (x^2 + 3y^2)(2 - x^2 - y^2).$$

1. Find all the critical points of f .
2. Identify the nature of the critical points provided.

1. Note that $f \in \mathcal{C}^1$. Therefore, to find the critical points of f we need to find where $\nabla f(x, y) = 0$. Therefore, we have

$$\nabla f(x, y) = 0 \iff \begin{cases} \frac{\partial f}{\partial x}(x, y) = 4x(1 - x^2 - 2y^2) = 0, \\ \frac{\partial f}{\partial y}(x, y) = 4y(3 - 2x^2 - 3y^2) = 0. \end{cases} \quad (6.2)$$

This system can generate four different scenarios as follows:

- $x = 0$ and $y = 0$.
- $x = 0$ and $3 - 2x^2 - 3y^2 = 0$. In this case, by substituting $x = 0$ in the second equation we find $y = -1$ $y = -1$.
- $y = 0$ and $1 - x^2 - 2y^2 = 0$. If we plug $y = 0$ into the second equation, we obtain $x = -1$ or $x = 1$.
- $x^2 + 2y^2 = 1$ and $2x^2 + 3y^2 = 3$. It follows from the first and second equations that $y^2 = -1$, which is impossible in \mathbb{R}^2 .

As result, f has five critical points: $(0, 0)$, $(-1, 0)$, $(1, 0)$; $(-1, 0)$, $(1, 0)$.

Next, since $f \in \mathcal{C}^2(\mathbb{R}^2)$, we can apply the second-derivative test. Therefore, we have

$$\frac{\partial^2 f}{\partial x^2}(x, y) = 4 - 1x^2 - 8y^2, \quad \frac{\partial f}{\partial y^2}(x, y) = 12 - 8x^2 - 36y^2, \quad \text{and} \quad \frac{\partial^2 f}{\partial x \partial y}(x, y) = -16xy.$$

- The critical point $(0, 0)$. We have

$$a = \frac{\partial^2 f}{\partial x^2}(0, 0) = 4 > 0, \quad b = \frac{\partial f}{\partial y^2}(0, 0) = 12, \quad c = \frac{\partial^2 f}{\partial x \partial y}(0, 0) = 0, \quad \implies \quad \mathbf{D} = 48 > 0.$$

Since $\mathbf{D} = 48 > 0$ and $a = 4 > 0$, f has a local minimum at the critical point $(0, 0)$.

- The critical points $(0, \pm 1)$. Here, we have $\mathbf{D} = 96 > 0$ and $a = -4 < 0$. Then, f has a local maximum at the points $(0, \pm 1)$.

- The critical points $(\pm 1, 0)$. In this case, we have $\mathbf{D} = -24 < 0$. Hence, the critical points $(\pm 1, 0)$ are saddle points of f .

Exercise 1.11. Given

$$f(x, y) = x^3 - 3xy^2 - 3x + 1.$$

Identify the nature of the critical points of f .

The critical points of the function f are given by the following system of two equations:

$$\nabla f(x, y) = 0 \iff \begin{cases} 3x^2 + 3y^2 - 3 = 0, \\ 6xy = 0. \end{cases}$$

From the second equation, it yields that $x = 0$ or $y = 0$. If $x = 0$, further, it follows from the first equation that $y = \pm 1$. On the other hand, if $y = 0$, it follows that $x = \pm 1$. Therefore, f has four critical points: $(-1, 0)$, $(1, 0)$, $(0, -1)$, $(0, 1)$.

Next, we move to apply the second-derivative test. First, we have

$$\frac{\partial^2 f}{\partial x^2}(x, y) = 6x, \quad \frac{\partial^2 f}{\partial y^2}(x, y) = 6x, \quad \text{and} \quad \frac{\partial^2 f}{\partial x \partial y}(x, y) = \frac{\partial^2 f}{\partial y \partial x}(x, y) = 6y.$$

- The critical point $(-1, 0)$. At this point, we have

$$a = \frac{\partial^2 f}{\partial x^2}(-1, 0) = -6 < 0, \quad b = \frac{\partial f}{\partial y^2}(-1, 0) = -6, \quad c = \frac{\partial^2 f}{\partial x \partial y}(-1, 0) = 0, \quad \implies \quad \mathbf{D} = 36 > 0.$$

Since $\mathbf{D} = 36 > 0$ and $a = -6 < 0$, at this point f has a local maximum.

- The critical point $(1, 0)$. At this point, we have

$$a = \frac{\partial^2 f}{\partial x^2}(1, 0) = 6 > 0, \quad b = \frac{\partial f}{\partial y^2}(1, 0) = 6, \quad c = \frac{\partial^2 f}{\partial x \partial y}(1, 0) = 0, \quad \implies \quad \mathbf{D} = 36 > 0.$$

Since $\mathbf{D} = 36 > 0$ and $a = 6 > 0$, at this point f has a local minimum.

- The critical point $(0, -1)$. Here, it follows that

$$a = \frac{\partial^2 f}{\partial x^2}(0, -1) = 0, \quad b = \frac{\partial f}{\partial y^2}(0, -1) = 0, \quad c = \frac{\partial^2 f}{\partial x \partial y}(0, -1) = -6, \quad \implies \quad \mathbf{D} = -36 < 0.$$

Since $\mathbf{D} = -36 < 0$, $(0, -1)$ is a saddle point of f .

- The critical point $(0, 1)$. Here, it follows that

$$a = \frac{\partial^2 f}{\partial x^2}(0, 1) = 0, \quad b = \frac{\partial f}{\partial y^2}(0, 1) = 0, \quad c = \frac{\partial^2 f}{\partial x \partial y}(0, 1) = 6, \quad \implies \quad \mathbf{D} = -36 < 0.$$

Since $\mathbf{D} = -36 < 0$, at this critical point f has a saddle point.

2 Absolute extrema

Definition 2.1. Let $f : D \subseteq \mathbb{R}^n \rightarrow \mathbb{R}$. We say

- (i) f has a an absolute (global) minimum at the point $x \in D$, if $f(x) \geq f(x_0)$, for all $x \in D$,
- (ii) f has a an absolute (global) maximum at the point $x \in D$, if $f(x) \leq f(x_0)$, for all $x \in D$.

Theorem 2.2. Let f be a continuous function in a closed and bounded set D . Then,

- (i) f has a maximum and a minimum in D .
- (ii) The absolute extrema must occur at critical points inside D or at boundary points of D .

Example 2.3. Find the absolute extrema of $f(x, y) = 2x^2 + y - 3xy$ in the region bounded by the lines: $y = x + 1$, $y = x - 1$, $y = 1 - x$ and $y = -1 - x$.

1. Find the critical points of f in D .

In order to determine the critical point of f we need to solve the following system :

$$\nabla f(x, y) = 0 \iff \begin{cases} 4x - 3y = 0, \\ 1 - 3x = 0. \end{cases}$$

It follows that f has a unique critical point $(\frac{1}{3}, \frac{4}{9})$. Obviously, it is inside the region D .

2. Analyzing the boundary of D .

The vertices of the region D are $(1, 0)$, $(0, 1)$, $(-1, 0)$ and $(0, -1)$. Thus, they can be considered as possible maxima or minima. Furthermore, one has to consider also the constraint extrema of f at each line.

For the first line $y = 1 - x$, it follows that:

$$g(x) = f(x, 1 - x) = 5x^2 - 4x + 1.$$

Therefore, $g'(x) = 10x - 4 = 0$ implies that $x = \frac{2}{5}$, and hence, $y = 1 - x = \frac{3}{5}$. That is, the point $(\frac{2}{5}, \frac{3}{5})$ is a point to be considered as a possible extrema. For the other lines, by a similar reasoning, we can determine the other points to be considered as a possible extrema as follows: $(-1, 0)$, $(2, 1)$, $(-\frac{1}{5}, \frac{4}{5})$

3. Choose the maximum and minimum values.

Now, we compare the value of the function at each point obtained as follows:

(a, b)	$(\frac{1}{3}, \frac{4}{9})$	$(0, 1)$	$(1, 0)$	$(-1, 0)$	$(0, -1)$	$(\frac{2}{5}, \frac{3}{5})$	$(-\frac{1}{5}, -\frac{4}{5})$	$(2, 1)$
$f(a, b)$	$\frac{2}{9}$	1	2	2	1	$\frac{1}{5}$	$-\frac{6}{5}$	3

Then, the absolute (global) maximum of $f(x, y)$ is 3 and occurs at the point $(2, 1)$, and the absolute (global) minimum of $f(x, y)$ is $-\frac{6}{5}$ and occurs at the point $(-\frac{1}{5}, -\frac{4}{5})$.

3 Lagrange multiplier

The Lagrange multiplier method is a technique used to find the extrema of a function $f : D \subseteq \mathbb{R}^n \rightarrow \mathbb{R}$ subject to a constraint of the form $g(x) = 0$. If we consider functions f two variables, we can explain the geometric interpretation of the Lagrange multiplier method as follows: determining the extrema of $f(x, y)$ subject to a constraint $g(x, y) = 0$, it means finding the extrema of $f(x, y)$ when the points (x, y) restricted to lie on the level curve $g(x, y) = 0$.

Theorem 3.1 (Critical point subject to a constraint). *Suppose that $f : D \subseteq \mathbb{R}^n \rightarrow \mathbb{R}$ has a local extremum at the point x_0 in the set defined by $\Delta = \{x \in D : g(x) = 0\}$. Moreover, suppose that g has continuous partial derivatives on a neighborhood of x_0 and $\nabla g(x_0) \neq 0$. If f is differentiable at the point x_0 , then there exists a number $\lambda \in \mathbb{R}$ such that*

$$\nabla f(x_0) = \lambda \nabla g(x_0).$$

The number λ is called a Lagrange multiplier.

Example 3.2. Find the extrema of $f(x, y) = x + y$ subject to the constraint $x^2 + y^2 = 1$.

The lagrangian function associate with this problem is given by

$$\begin{aligned} L(x, y, \lambda) &= f(x, y) + \lambda g(x, y) \\ &= x + y + \lambda(x^2 + y^2 - 1). \end{aligned}$$

Next, we move to solve $\nabla L(x, y, \lambda) = 0$. That is :

$$\nabla L(x, y, \lambda) = 0 \iff \begin{cases} 1 + 2\lambda x = 0, \\ 1 + 2\lambda y = 0, \\ x^2 + y^2 = 1. \end{cases}$$

From the first and second equations, we find $x = -\frac{1}{2\lambda}$ and $y = -\frac{1}{2\lambda}$, respectively. Then, by substituting them into the third equation, we obtain $\lambda = \pm \frac{1}{\sqrt{2}}$. Hence, we get the solution $(x, y) = \left(\frac{\sqrt{2}}{2}, \frac{\sqrt{2}}{2}\right)$ and $\left(-\frac{\sqrt{2}}{2}, -\frac{\sqrt{2}}{2}\right)$.

Notice that the constraint is a closed and bounded curve, and hence, we can only consider the points in the curve $x^2 + y^2 = 1$. Therefore, we can evaluate the value of f at these points to determine the extrema values of f subject to the constraint $g(x, y) = 0$. Son, we have $f\left(\frac{\sqrt{2}}{2}, \frac{\sqrt{2}}{2}\right) = 2\sqrt{2}$, and $f\left(-\frac{\sqrt{2}}{2}, -\frac{\sqrt{2}}{2}\right) = -2\sqrt{2}$. Thus, f attains its minimum on $x^2 + y^2 = 1$ at the point $\left(-\frac{\sqrt{2}}{2}, -\frac{\sqrt{2}}{2}\right)$ and f has a maximum on $x^2 + y^2 = 1$ at the point $\left(\frac{\sqrt{2}}{2}, \frac{\sqrt{2}}{2}\right)$.

4 Exercises

Exercise 4.1. Determine and classify the critical points of each of the following functions:

(a) $f(x, y) = x^2 + y^2 + xy + x - y + 1,$

(b) $f(x, y) = (x^2 + y^2)e^{x^2 - y^2},$

(c)

(d)

(e)

(f)

Solutions. (a) The critical points of the function $f(x, y) = x^2 + y^2 + xy + x - y + 1$ occur when $\nabla f(x, y) = 0$, (i.e., $\frac{\partial f}{\partial x}(x, y) = 0$ and $\frac{\partial f}{\partial y}(x, y) = 0$). That is

$$\begin{cases} 2x + y + 1 = 0, \\ 2y + x - 1 = 0. \end{cases}$$

Therefore, by elimination we find that $2(1 - 2y) + (y + 1) = 0$, and hence, we obtain $y = 1$ and then $x = -1$. Thus, f has only one critical point $(-1, 1)$.

Next, we have

$$\frac{\partial^2 f}{\partial x^2}(-1, 1) = 2, \quad \frac{\partial^2 f}{\partial y^2}(-1, 1) = 2, \quad \text{and} \quad \frac{\partial^2 f}{\partial x \partial y}(-1, 1) = 1.$$

Thus, we get $\mathbf{D} = ab - c^2 = 4 - 1 = 3 > 0$. Since $a > 0$ and $\mathbf{D} > 0$, via the second-derivative test f has a local minimum at the critical point $(-1, 1)$.

(b) To determine the critical points of $f(x, y) = (x^2 + y^2)e^{x^2 - y^2}$, one needs to solve the following system equations:

$$\begin{cases} \frac{\partial f}{\partial x}(x, y) = 2x(x^2 + y^2 + 1)e^{x^2 - y^2} = 0, \\ \frac{\partial f}{\partial y}(x, y) = 2y(1 - x^2 - y^2)e^{x^2 - y^2} = 0. \end{cases}$$

Then, it can be observed that f has three critical points $(0, 0)$, $(0, -1)$ and $(0, 1)$. Next, via the second-derivative test, we determine the nature of this critical point as follows:

• For the critical point $(0, 0)$: We have

$$a = \left. \frac{\partial^2 f}{\partial x^2}(x, y) \right|_{(0,0)} = [(4x^2 + 2)(x^2 + y^2) + 8x^2 + 2] e^{x^2 - y^2} \Big|_{(0,0)} = 2,$$

and

$$b = \left. \frac{\partial^2 f}{\partial y^2}(x, y) \right|_{(0,0)} = [(4y^2 - 2)(x^2 + y^2) - 8y^2 + 2] e^{x^2 - y^2} \Big|_{(0,0)} = 2.$$

Moreover, we have

$$c = \frac{\partial^2 f}{\partial x \partial y}(x, y) \Big|_{(0,0)} = -4x(x^2 + y^2)e^{x^2 - y^2} \Big|_{(0,0)} = 0.$$

Therefore, $\mathbf{D} = ab - c^2 = 4 > 0$. Notice that $a > 0$ and $\mathbf{D} > 0$, then f has a local minimum at the point $(0, 0)$.

• For the critical points $(0, \pm 1)$: We have

$$a = \frac{\partial^2 f}{\partial x^2}(0, \pm 1) = \frac{4}{e}, \quad b = \frac{\partial^2 f}{\partial y^2}(0, \pm 1) = -\frac{4}{e}, \quad \text{and } c = \frac{\partial^2 f}{\partial x \partial y}(0, \pm 1) = 0.$$

Thus, it results $D = -\frac{16}{e^2} < 0$. Then, $(0, \pm 1)$ is saddle point.

(c) First, we determine the critical points of $f(x, y, z) = 2xy^2 - 4xy + x^2 + z^2 - 2z$. The equation $\nabla f(x, y, z) = 0$ gives

$$\begin{cases} \frac{\partial f}{\partial x}(x, y, z) = 2y^2 - 4y + 2x = 0, \\ \frac{\partial f}{\partial y}(x, y, z) = 4xy - 4x = 0, \\ \frac{\partial f}{\partial z}(x, y, z) = 4z - 2 = 0. \end{cases}$$

From the third equation, it yields $z = 1$. Next, from the second equation, we have $x = 0$ or $y = 1$. So, by plugging $x = 0$ into the first equation we find $y = 0$ or $y = 2$, and if $y = 1$, it yields that $x = 1$. Thus, we get three critical points: $(0, 0, 1)$, $(0, 2, 1)$ and $(1, 1, 1)$.

Now, we move to classify the critical points. To this end, we find and evaluate the Hessian matrix of f at each critical point. Therefore, we have

$$H_{ess}f(x, y, z) = \begin{pmatrix} \frac{\partial^2 f}{\partial x^2}(x, y, z) & \frac{\partial^2 f}{\partial x \partial y}(x, y, z) & \frac{\partial^2 f}{\partial x \partial z}(x, y, z) \\ \frac{\partial^2 f}{\partial y \partial x}(x, y, z) & \frac{\partial^2 f}{\partial y^2}(x, y, z) & \frac{\partial^2 f}{\partial y \partial z}(x, y, z) \\ \frac{\partial^2 f}{\partial z \partial x}(x, y, z) & \frac{\partial^2 f}{\partial z \partial y}(x, y, z) & \frac{\partial^2 f}{\partial z^2}(x, y, z) \end{pmatrix} = \begin{pmatrix} 2 & 4y - y & 0 \\ 4y - y & 4x & 0 \\ 0 & 0 & 2 \end{pmatrix}$$

Here we go:

• The critical point $(0, 0, 1)$: The Hessian matrix at this point is given as

$$H_{ess}f(0, 0, 1) = \begin{pmatrix} 2 & -4 & 0 \\ -4 & 0 & 0 \\ 0 & 0 & 2 \end{pmatrix}.$$

Then, the characteristic equation of $H_{ess}f(0, 0, 1)$ is expressed by

$$P(\lambda) = \det \begin{pmatrix} 2 - \lambda & -4 & 0 \\ -4 & -\lambda & 0 \\ 0 & 0 & 2 - \lambda \end{pmatrix}$$

So, $P(\lambda) = (2 - \lambda)(\lambda^2 - 2\lambda - 16)$. Thus, it yields $\lambda_1 = 2$, $\lambda_2 = 1 - \sqrt{17}$ and $\lambda_3 = 1 + \sqrt{17}$.

- The critical point $(0, 2, 1)$: The Hessian matrix at $(0, 2, 1)$ is given as:

$$H_{ess}f(0, 2, 1) = \begin{pmatrix} 2 & 4 & 0 \\ 4 & 0 & 0 \\ 0 & 0 & 2 \end{pmatrix}.$$

Then, the characteristic equation of $H_{ess}f(0, 2, 1)$ is expressed by

$$P(\lambda) = \det \begin{pmatrix} 2 - \lambda & 4 & 0 \\ 4 & -\lambda & 0 \\ 0 & 0 & 2 - \lambda \end{pmatrix}$$

Similarly, we have $P(\lambda) = (2 - \lambda)(\lambda^2 - 2\lambda - 16)$, and hence, $\lambda_1 = 2$, $\lambda_2 = 1 - \sqrt{17}$ and $\lambda_3 = 1 + \sqrt{17}$.

- The critical point $(0, 1, 1)$: The Hessian matrix at $(0, 1, 1)$ is given as:

$$H_{ess}f(0, 1, 1) = \begin{pmatrix} 2 & 0 & 0 \\ 0 & 4 & 0 \\ 0 & 0 & 2 \end{pmatrix}.$$

Then, the characteristic equation of $H_{ess}f(0, 1, 1)$ is expressed by

$$P(\lambda) = \det \begin{pmatrix} 2 - \lambda & 0 & 0 \\ 0 & 4 - \lambda & 0 \\ 0 & 0 & 2 - \lambda \end{pmatrix}$$

Therefore, $P(\lambda) = (2 - \lambda)^2(4 - \lambda)$. Then, it yields $\lambda_{1,2} = 2$, $\lambda_3 = 4$.

Chapter 7

Multiple Integrals

1 Double integral

Let $f(x, y)$ be a continuous function defined over the rectangle

$$\begin{aligned} R &= [a, b] \times [c, d] \\ &= \{(x, y) \in \mathbb{R}^2 : a \leq x \leq b, c \leq y \leq d\}. \end{aligned}$$

Let P be the partition of the rectangle R into subrectangles $R_{i,j}$, $i = 1, \dots, n$, $j = 1, \dots, m$, where

$$R_{i,j} = [x_i, x_{i+1}] \times [y_j, y_{j+1}], \quad i = 1, \dots, n, \quad j = 1, \dots, m,$$

such that

$$x_i = a + i\Delta x \quad \text{and} \quad y_j = c + j\Delta y,$$

with

$$\Delta x = \frac{b-a}{n} \quad \text{and} \quad \Delta y = \frac{d-c}{m},$$

so that there are $n \times m$ partitions of the rectangle R .

Assuming $f(x, y) \geq 0$. Then, the graph of $f(x, y)$ is curved above the rectangle R , and at the point (x, y) the highest of the surface is given by $z = f(x, y)$. Now, over each partition $R_{i,j}$, we construct a cube whose height is given by $z = f(x_{ij}^*, y_{ij}^*)$ and base $\Delta A = \Delta x \Delta y$, where

$$\{(x_{ij}^*, y_{ij}^*) \in R_{i,j}, 1 \leq i \leq n, 1 \leq j \leq m\}$$

is the collection of sample points. Therefore, the volume of each cube is given by: $f(x_{ij}^*, y_{ij}^*) \Delta A$, and hence, the volume under the graph of $f(x, y)$ is then approximately

$$V \simeq \sum_{i=1}^n \sum_{j=1}^m f(x_{ij}^*, y_{ij}^*) \Delta A.$$

Now, by taking limit as $\Delta x \rightarrow 0$ and $\Delta y \rightarrow 0$. The height $z = f(x, y)$ is nearly constant over each rectangle. Then, the sum approaches a limit, which depends only on the base R and the surface above it. The limit is the volume of the solid, and it is the double integral of $f(x, y)$ over the rectangle R , and hence we write

$$\iint_R f(x, y) \Delta A = \lim_{\substack{\Delta x \rightarrow 0 \\ \Delta y \rightarrow 0}} \sum_{i=1}^n \sum_{j=1}^m f(x_{ij}^*, y_{ij}^*) \Delta A.$$

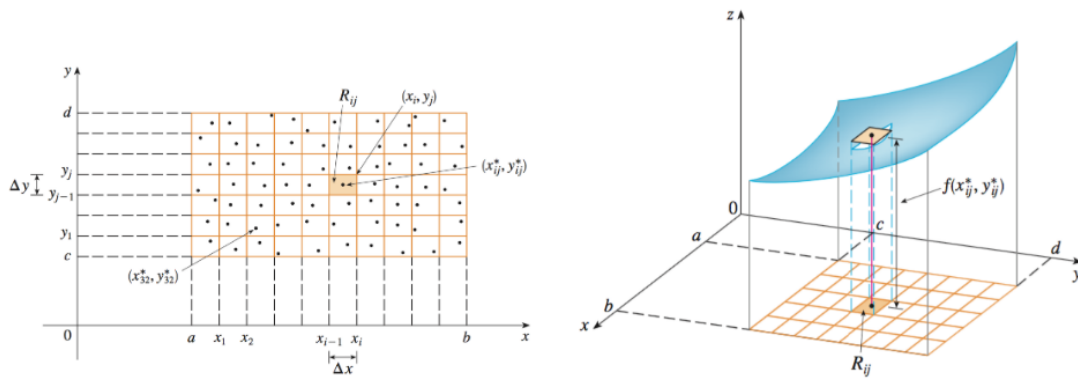

Figure 7.1: Partition of the rectangle R

The double integral $\iint_R f(x, y) \Delta A$ can be expressed as follows

$$\iint_R f(x, y) dx dy, \quad \text{or} \quad \iint_R f(x, y) dy dx.$$

Properties of Double Integrals:

- (i) $\iint_R (f(x, y) + g(x, y)) \Delta A = \iint_R f(x, y) \Delta A + \iint_R g(x, y) \Delta A$,
- (ii) $\iint_R \alpha f(x, y) \Delta A = \alpha \iint_R f(x, y) \Delta A, \quad \alpha \in \mathbb{R}$,
- (iii) If $f(x, y) \geq g(x, y)$ for all $(x, y) \in D$, then $\iint_R f(x, y) \Delta A \geq \iint_R g(x, y) \Delta A$.

Theorem 1.1 (Fubini's Theorem). *If f is continuous function on the rectangle*

$$R = \{(x, y) \in \mathbb{R}^2 : a \leq x \leq b, c \leq y \leq d\}$$

then, we have

$$\iint_R f(x, y) \Delta A = \int_a^b \int_c^d f(x, y) dy dx = \int_c^d \int_a^b f(x, y) dx dy.$$

Example 1.2. *Evaluate the double integral*

$$\iint_R (x - 3y^2) \Delta A,$$

where $R = [0, 2] \times [1, 2]$.

By Fubini's Theorem, we have

$$\begin{aligned}
 \iint_{\mathbf{R}} (x - 3y^2) \Delta A &= \int_0^2 \int_1^2 (x - 3y^2) dy dx \\
 &= \int_0^2 (xy - y^3) \Big|_1^2 dx \\
 &= \int_0^2 [(x - 8) - (x - 1)] dx \\
 &= \int_0^2 (x - 7) dx \\
 &= \left(\frac{x^2}{2} - 7x \right) \Big|_0^2 \\
 &= -12.
 \end{aligned}$$

• If f can be expressed as $f(x, y) = f_1(x)f_2(y)$, and we are integrating over the rectangle $\mathbf{R} = \{(x, y) \in \mathbb{R}^2 : a \leq x \leq b, c \leq y \leq d\}$, then, we have

$$\begin{aligned}
 \iint_{\mathbf{R}} f(x, y) \Delta A &= \iint_{\mathbf{R}} f_1(x)f_2(y) \Delta A \\
 &= \left(\int_a^b f_1(x) dx \right) \left(\int_c^d f_2(y) dy \right).
 \end{aligned}$$

2 Double integrals over general regions

Double integrals over non-rectangular regions have the same meaning as double integrals over rectangles. Given a function $f(x, y)$ and a region \mathbf{D} in the xy -plane, the double integral $\iint_{\mathbf{D}} f(x, y) \Delta A$ gives the volume of the solid that is bounded by the graph of the function f and the region \mathbf{D} . Fubini's Theorem still applies, which means that we can compute these integrals using iterated integrals.

Theorem 2.1 (Fubini's Theorem (Strong Form)). *Suppose that f is continuous function on a region*

$$\mathbf{D} = \{(x, y) \in \mathbb{R}^2 : a \leq x \leq y, \varphi_1(x) \leq y \leq \varphi_2(x)\}.$$

Then, we have

$$\iint_{\mathbf{D}} f(x, y) \Delta A = \iint_{\mathbf{D}} f(x, y) dx dy = \int_a^b \left[\int_{\varphi_1(x)}^{\varphi_2(x)} f(x, y) dy \right] dx.$$

Similarly, we have

Theorem 2.2 (Fubini's Theorem (Strong Form)). *Suppose that f is continuous function on a region*

$$\mathbf{D} = \{(x, y) \in \mathbb{R}^2 : c \leq y \leq d, \psi_1(y) \leq x \leq \psi_2(y)\}.$$

Then, we have

$$\iint_{\mathbf{D}} f(x, y) \Delta A = \iint_{\mathbf{D}} f(x, y) dx dy = \int_c^d \left[\int_{\psi_1(y)}^{\psi_2(y)} f(x, y) dx \right] dy.$$

Example 2.3. Evaluate the double integral $\iint_D x^2 e^{xy} \Delta A$, where

$$D = \left\{ (x, y) \in \mathbb{R}^2 : 0 \leq x \leq 2, \frac{1}{2}x \leq y \leq 1 \right\}.$$

Observe that $D = \{(x, y) \in \mathbb{R}^2 : 0 \leq x \leq 2, \frac{1}{2}x \leq y \leq 1\}$. Then, we have

$$\begin{aligned} \iint_D x^2 e^{xy} \Delta A &= \int_0^2 \left[\int_{\frac{1}{2}x}^1 x^2 e^{xy} dy \right] dx \\ &= \int_0^2 [xe^{xy}] \Big|_{y=\frac{1}{2}x}^{y=1} dx \\ &= \int_0^2 [xe^x - x^{\frac{x^2}{2}}] dx \\ &= [xe^x - e^x - e^{\frac{1}{2}x^2}] \Big|_0^2 \\ &= 2. \end{aligned}$$

Example 2.4. Evaluate the double integral: $\iint_D \frac{xy}{1+x^2+y^2} \Delta A$, with

$$D = \{(x, y) \in \mathbb{R}^2 : 0 \leq x \leq 1, \sqrt{1-x^2} \leq y \leq 1\}.$$

We have:

$$\begin{aligned} \iint_D \frac{xy}{1+x^2+y^2} \Delta A &= \int_0^1 \left[\int_{\sqrt{1-x^2}}^1 \frac{xy}{1+x^2+y^2} dy \right] dx \\ &= \int_0^1 \left[\frac{x}{2} \ln(2+x^2) - \frac{x}{2} \ln(2) \right] \Big|_{y=\sqrt{1-x^2}}^{y=1} dx \\ &= \int_0^1 \frac{x}{2} \ln(x^2+2) dx - \frac{\ln(2)}{2} \int_0^1 x dx \\ &= \frac{1}{4} [(x^2+2) \ln(x^2+2) - x^2 - 1] \Big|_0^1 - \frac{\ln(2)}{4} \\ &= \frac{3}{4} \ln \frac{3}{2} - \frac{1}{4}. \end{aligned}$$

3 Change the order of the integration

- If the limits of integration in a double integral are constants (i.e., integrating over a rectangle $R = [a, b] \times [c, d]$), then the order of integration can be changed, provided the

relevant limits are taken for the concerned variables. That is

$$\int_a^b \int_c^d f(x, y) dy dx = \int_c^d \int_a^b f(x, y) dx dy.$$

• When the limits for inner integration are functions (i.e., integrating over general region D), the change in the order of integration will result in changes in the limits of integration. That is

$$\int_a^b \int_{\varphi_1(x)}^{\varphi_2(x)} f(x, y) dy dx = \int_c^d \int_{\psi_1(y)}^{\psi_2(y)} f(x, y) dx dy.$$

Example 3.1. Change the order of the integration and evaluate the following double integral:

$$\int_0^3 \int_1^{\sqrt{4-y}} (x + y) dx dy.$$

By changing the order of integration, the region

$$D = \{(x, y) \in \mathbb{R}^2 : 0 \leq y \leq 3, 1 \leq x \leq \sqrt{4-y}\}$$

becomes

$$D = \{(x, y) \in \mathbb{R}^2 : 1 \leq x \leq 2, 0 \leq y \leq 4 - x^2\}.$$

Therefore, we obtain

$$\int_0^3 \int_1^{\sqrt{4-y}} (x + y) dx dy = \int_1^2 \int_0^{4-x^2} (x + y) dy dx$$

Then,

$$\begin{aligned} \int_1^2 \int_0^{4-x^2} (x + y) dy dx &= \int_1^2 \left[\int_0^{4-x^2} (x + y) dy \right] dx \\ &= \int_1^2 \left[xy + \frac{y^2}{2} \right] \Big|_{y=0}^{y=4-x^2} dx \\ &= \int_1^2 \left[\frac{x^4}{2} - x^3 - 4x^2 + 4x + 8 \right] dx \\ &= \left[\frac{x^5}{10} - \frac{x^4}{4} - \frac{4}{3}x^3 + 2x^2 + 8x \right] \Big|_{x=1}^{x=2} \\ &= \frac{241}{8}. \end{aligned}$$

4 Volumes and area using double integral

Example 4.1. Find the volume of the solid bounded by the planes $x = 0$, $y = 0$, $z = 0$, and $2x + y + z = 6$.

The solide is a tetrahedon with the base on the xy -plane and the height $z = 6 - 2x - 3y$. The base is teh region D bounded by $x = 0$, $y = 0$, and $2x + 6y = 6$. Therefore, the region D can be given as

$$D = \left\{ (x, y) \in \mathbb{R}^2 : 0 \leq x \leq 3, 0 \leq y \leq 2 - \frac{2}{3}x \right\}.$$

Then, the volume is

$$\begin{aligned} V &= \int_0^3 \left[\int_0^{2-2/3x} (6 - 2x - 3y) dy \right] dx \\ &= \int_0^3 \left[6y - 2xy - \frac{3}{2}y^2 \right] \Big|_{y=0}^{y=2-2/3x} dx \\ &= \int_0^3 \frac{2}{3}(x - 3)^2 dx \\ &= 6. \end{aligned}$$

Example 4.2. Find the area between the parabola $y = 4x - x^2$ and the line $y = x$.

Given, $y = 4x - x^2$ and $y = x$. Then, we can get $x(3 - x) = 0$, which implies that $x = 0, 3$. Therefore, we have

$$\begin{aligned} A &= \int_0^3 \left[\int_x^{4x-x^2} dy \right] dx \\ &= \int_0^3 y \Big|_{y=x}^{y=4x-x^2} dx \\ &= \int_0^3 (3x - x^3) dx \\ &= \left[\frac{2}{3}x^2 - \frac{1}{3}x^3 \right] \Big|_{x=0}^{x=3} \\ &= \frac{9}{2}. \end{aligned}$$

5 Change of variable in double integral

In the following, we consider the change of variables in double integrals. Note that, for multi-variable domains, the change of variable is a transformation. Typical examples consist of changing the two-dimensional Cartesian coordinate into the polar coordinate and changing the three-dimensional Cartesian coordinates into cylindrical or spherical coordinates. Generally, a transformation T is a mapping from the uv -plane into the xy -plane, say $(x, y) = T(u, v)$. T is called one-to-one if no two points have the same image. When T is one-to-one, we write T^{-1} for the inverse transformation of T that maps points from the xy -plane into the uv -plane.

Definition 5.1. The Jacobian of a transformation $(x, y) = (g(u, v), h(u, v))$ is given as

$$\frac{\partial(x, y)}{\partial(u, v)} = \begin{vmatrix} \frac{\partial x}{\partial u} & \frac{\partial x}{\partial v} \\ \frac{\partial y}{\partial u} & \frac{\partial y}{\partial v} \end{vmatrix} = \frac{\partial x}{\partial u} \frac{\partial y}{\partial v} - \frac{\partial x}{\partial v} \frac{\partial y}{\partial u}.$$

Theorem 5.2 (Change of variables in double integrals). Let $(x, y) = T(u, v) = (g(u, v), h(u, v))$ be a continuously differentiable transformation of the plane that is one to one from a region D' in the uv -plane to a region D in the xy -plane. If the Jacobian of T is non-zero on D , then we have:

$$\iint_D f(x, y) dA(x, y) = \iint_{D'} f(g(u, v), h(u, v)) \left| \frac{\partial(x, y)}{\partial(u, v)} \right| dA(u, v).$$

- We use the notation $dA(x, y)$ and $dA(u, v)$ to denote the area element in the (x, y) and (u, v) coordinates, respectively.

Example 5.3. Use the transformation given by $x = 2u + v$ and $y = u + 2v$ to compute the double integral $\iint_D (x - 3y) dA$, where D is the triangular region with vertices $(0, 0)$, $(1, 2)$ and $(2, 1)$.

First of all, notice that

$$\frac{\partial(x, y)}{\partial(u, v)} = \begin{vmatrix} 2 & 1 \\ 1 & 2 \end{vmatrix} = 3 \neq 0.$$

Therefore, we have

$$\begin{aligned} \iint_D (x - 3y) dA(x, y) &= \iint_{D'} [(2u + v) - 3(u + 2v)] \left| \frac{\partial(x, y)}{\partial(u, v)} \right| dA(u, v) \\ &= \iint_{D'} -3(u + 5v) dA(u, v) \end{aligned}$$

Next, we move to determine the region D' . From the transformation $x = 2u + v$ and $y = u + 2v$, we can get

$$u = \frac{1}{3}(2x - y) \quad \text{and} \quad v = \frac{1}{3}(x - 2y).$$

Therefore, it follows:

$$\begin{aligned} \iint_{D'} -3(u + 5v) dA &= \int_0^1 \left[\int_0^{1-u} -3(u + 5v) dv \right] du \\ &= -3 \int_0^1 \left(uv + \frac{5}{2}v^2 \right) \Big|_{v=0}^{v=1-u} du \\ &= -3 \int_0^1 \left(u(1-u) + \frac{5}{2}(1-u)^2 \right) du \\ &= -3 \left(\frac{1}{2}u^2 - \frac{1}{3}u^3 - \frac{5}{6}(1-u)^3 \right) \Big|_{u=0}^{u=1} \\ &= -3. \end{aligned}$$

Example 5.4. Evaluate the double integral $\iint_D e^{\frac{x-y}{x+y}} dA$, where

$$D = \{(x, y) \in \mathbb{R}^2 : x \geq 0, y \geq 0, x + y \leq 1\}.$$

Observe that evaluation the double integral without changing of variables seems probably impossible. So, to deal with this double integral we need to consider the following change of variables :

$$u = x - y \quad \text{and} \quad v = x + y.$$

It follows then

$$x = x(u, v) = \frac{1}{2}(u + v) \quad \text{and} \quad y = y(u, v) = \frac{1}{2}(v - u).$$

Hence, we get a new region in uv -plane

$$D' = \{(u, v) \in \mathbb{R}^2 : -v \leq u \leq v, 0 \leq v \leq 1\}.$$

Now, notice that

$$\det \mathbf{J}(u, v) = \begin{vmatrix} \frac{\partial x}{\partial u}(u, v) & \frac{\partial x}{\partial v}(u, v) \\ \frac{\partial y}{\partial u}(u, v) & \frac{\partial y}{\partial v}(u, v) \end{vmatrix} = \begin{vmatrix} \frac{1}{2} & \frac{1}{2} \\ -\frac{1}{2} & \frac{1}{2} \end{vmatrix} = \frac{1}{2}.$$

Therefore, it yields the following

$$\begin{aligned} \iint_D e^{\frac{x-y}{x+y}} dA &= \iint_{D'} f(x(u, v), y(u, v)) |\det \mathbf{J}(u, v)| dA \\ &= \int_0^1 \left[\int_{-v}^v \frac{1}{2} e^{\frac{u}{v}} du \right] dv \\ &= \int_0^1 \frac{v}{2} e^{\frac{u}{v}} \Big|_{u=-v}^{u=v} dv \\ &= \int_0^1 \frac{1}{2} (e - e^{-1}) v dv \\ &= \frac{1}{4} (e - e^{-1}) v^2 \Big|_0^1 \\ &= \frac{e^2 - 1}{4}. \end{aligned}$$

Special case: Polar coordinate

The polar coordinate transformation is usually used to represent points in a two-dimensional space. In polar coordinates, each point $P = (x, y)$ in the plane is assigned a pair of coordinates (r, θ) , where r is the distance from the origin $(0, 0)$ to P , and θ is the angle between the positive x -axis and the vector having initial point at the origin and terminal point P . In all quadrants, the transformation from polar coordinates to standard (rectangular) coordinates is given by

$$x = r \cos \theta \quad \text{and} \quad y = r \sin \theta.$$

We can also convert from rectangular coordinates to polar coordinates as

$$r = \sqrt{x^2 + y^2} \quad \text{and} \quad \theta = \arctan \frac{y}{x}, \quad x \neq 0.$$

Now, observe that

$$\frac{\partial(x, y)}{\partial(r, \theta)} = \begin{vmatrix} \frac{\partial x}{\partial r}(r, \theta) & \frac{\partial x}{\partial \theta}(r, \theta) \\ \frac{\partial y}{\partial r}(r, \theta) & \frac{\partial y}{\partial \theta}(r, \theta) \end{vmatrix} = \begin{vmatrix} \cos \theta & -r \sin \theta \\ \sin \theta & r \cos \theta \end{vmatrix} = r \cos^2 \theta + r \sin^2 \theta = r \neq 0.$$

Therefore, we have

$$\begin{aligned} \iint_{\mathbf{D}} f(x, y) dA(x, y) &= \iint_{\mathbf{D}'} f(x(r, \theta), y(r, \theta)) \left| \frac{\partial(x, y)}{\partial(r, \theta)} \right| dA(r, \theta) \\ &= \iint_{\mathbf{D}'} f(x(r, \theta), y(r, \theta)) r dr d\theta, \end{aligned}$$

where \mathbf{D}' is the region in the polar coordinate plane corresponding to the region \mathbf{D} .

Example 5.5. *By passing to the polar coordinate, evaluate*

$$\iint_{\mathbf{D}} e^{-x^2 - y^2} dA,$$

where \mathbf{D} is bounded by $x = \sqrt{4 - y^2}$ and the y -axis.

Consider the transformation $x = r \cos \theta$ and $y = r \sin \theta$. Then, we have

$$\frac{\partial(x, y)}{\partial(r, \theta)} = \begin{vmatrix} \cos \theta & -r \sin \theta \\ \sin \theta & r \cos \theta \end{vmatrix} = r \cos^2 \theta + r \sin^2 \theta = r \neq 0.$$

Therefore, it follows that

$$\iint_{\mathbf{D}} e^{-x^2 - y^2} dA(x, y) = \iint_{\mathbf{D}'} e^{-r^2} r dA(r, \theta).$$

Let us determine the region \mathbf{D}' . Since $x = \sqrt{4 - y^2}$, then, $0 < r \leq 2$. Moreover, it yields that $-\frac{\pi}{2} \leq \theta \leq \frac{\pi}{2}$. Then, we get

$$\begin{aligned} \iint_{\mathbf{D}'} e^{-r^2} r dA(r, \theta) &= \int_0^2 \int_{-\frac{\pi}{2}}^{\frac{\pi}{2}} r e^{-r^2} d\theta dr \\ &= \left(\int_{-\frac{\pi}{2}}^{\frac{\pi}{2}} d\theta \right) \left(\int_0^2 r e^{-r^2} dr \right) \\ &= \pi \left(-\frac{1}{2} e^{-r^2} \Big|_0^2 \right) \\ &= \frac{\pi}{2} (1 - e^{-4}). \end{aligned}$$

6 Triple integral

Similar to the way that we defined the double integrals for functions of two variables, we can also define triple integrals for functions of three variables.

Let f be a continuous function defined on a rectangular cube

$$\begin{aligned} B &= [a, b] \times [c, d] \times [s, t] \\ &= \{(x, y, z) \in \mathbb{R}^3 : a \leq x \leq b, c \leq y \leq d, s \leq z \leq t\}. \end{aligned}$$

We divide the rectangular cube B into sub-cubes

$$B_{i,j,k} = [x_i, x_{i+1}] \times [y_j, y_{j+1}] \times [z_k, z_{k+1}],$$

for all $i = 1, \dots, n$, $j = 1, \dots, m$, and $k = 1, \dots, p$, such that

$$x_i = a + i\Delta x, \quad y_j = c + j\Delta y, \quad \text{and} \quad z_k = s + k\Delta z,$$

with

$$\Delta x = \frac{b-a}{n}, \quad \Delta y = \frac{d-c}{m}, \quad \text{and} \quad \Delta z = \frac{t-s}{p}.$$

Let $\Delta V = \Delta x \Delta y \Delta z$, and let $(x_{ijk}^*, y_{ijk}^*, z_{ijk}^*)$ denote a sample point in each region B_{ijk} . If the following limit

$$\lim_{\substack{\Delta x \rightarrow 0 \\ \Delta y \rightarrow 0 \\ \Delta z \rightarrow 0}} \sum_{i=1}^n \sum_{j=1}^m \sum_{k=1}^p f(x_{ijk}^*, y_{ijk}^*, z_{ijk}^*) \Delta x \Delta y \Delta z.$$

exists, then the function $f(x, y, z)$ is said to be Riemann integrable and the triple integral of f over B is given by

$$\iiint_B f(x, y, z) dV = \lim_{\substack{\Delta x \rightarrow 0 \\ \Delta y \rightarrow 0 \\ \Delta z \rightarrow 0}} \sum_{i=1}^n \sum_{j=1}^m \sum_{k=1}^p f(x_{ijk}^*, y_{ijk}^*, z_{ijk}^*) \Delta V.$$

Theorem 6.1. *If f is continuous function on a rectangular cube $B = [a, b] \times [c, d] \times [s, t]$, then, we have*

$$\iiint_B f(x, y, z) dV = \int_s^t \int_c^d \int_a^b f(x, y, z) dx dy dz.$$

• It means that we began integration w.r.t x , then w.r.t y , and then w.r.t z . Remember that we can change the order of integration w.r.t any of these independent variables.

Example 6.2. Evaluate the triple integral $\iiint_B xy^2 z dV$, where B is given as

$$B = \{(x, y, z) \in \mathbb{R}^3 : 0 \leq x \leq 1, 0 \leq y \leq 3, -1 \leq z \leq 2\}.$$

Since B is rectangular cube, we can pick any order of integration. So, let us proceed with $dx dy dz$ version:

$$\begin{aligned}
 \iiint_B xy^2 z dV &= \int_{-1}^2 \int_0^3 \int_0^1 xy^2 z dx dy dz \\
 &= \int_{-1}^2 \int_0^3 \frac{1}{2} x^2 y^2 z \Big|_{x=0}^{x=1} dy dz \\
 &= \frac{1}{2} \int_{-1}^2 \int_0^3 y^2 z dy dz \\
 &= \frac{1}{2} \int_{-1}^2 \left[\frac{1}{3} y^3 z \right]_{y=0}^3 dz \\
 &= \frac{9}{2} \int_{-1}^2 z dz \\
 &= \frac{9}{2} \frac{1}{2} z^2 \Big|_{z=-1}^{z=2} \\
 &= \frac{27}{4}.
 \end{aligned}$$

7 Triple integrals over general bounded solids

We will consider three main ways of describing domains and how triple integrals are written on them. Just like in double integrals, a domain might be able to be described in more than one ways or even in none of them.

- First possibility:

Theorem 7.1. *Let E be written in the form*

$$E = \{(x, y, z) \in \mathbb{R}^3 : (x, y) \in D, \varphi_1(x, y) \leq z \leq \varphi_2(x, y)\}$$

Suppose $f(x, y, z)$ is a continuous function on E . Then, we have

$$\iiint_E f(x, y, z) dV = \iint_D \left[\int_{\varphi_1(x, y)}^{\varphi_2(x, y)} f(x, y, z) dz \right] dA.$$

- Second possibility:

Theorem 7.2. *Let E be written in the form*

$$E = \{(x, y, z) \in \mathbb{R}^3 : (x, z) \in D, \psi_1(x, z) \leq y \leq \psi_2(x, z)\}$$

Suppose $f(x, y, z)$ is a continuous function on E . Then, we have

$$\iiint_E f(x, y, z) dV = \iint_D \left[\int_{\psi_1(x, z)}^{\psi_2(x, z)} f(x, y, z) dy \right] dA.$$

- Third possibility:

Theorem 7.3. Let E be written in the form

$$E = \{(x, y, z) \in \mathbb{R}^3 : (x, z) \in D, \xi_1(y, z) \leq x \leq \xi_2(y, z)\}$$

Suppose $f(x, y, z)$ is a continuous function on E . Then, we have

$$\iiint_E f(x, y, z) dV = \iint_D \left[\int_{\xi_1(y, z)}^{\xi_2(y, z)} f(x, y, z) dx \right] dA.$$

Each of the theorems above tells us that the calculation of the triple integral boils down to setting up a double integral. For example, in Theorem 7.1, if

$$D = \{(x, y) \in \mathbb{R}^2 : a \leq x \leq b, u_1(x) \leq y \leq u_2(x)\}$$

then, we have

$$\iiint_E f(x, y, z) dV = \int_a^b \int_{u_1(x)}^{u_2(x)} \int_{\varphi_1(x, y)}^{\varphi_2(x, y)} f(x, y, z) dz dy dx.$$

Example 7.4. Set up the integral of the function $f(x, y, z)$, which is defined on the solid E bounded by the surfaces $x^2 + y^2 + z^2 = 1$, $z = 0$ and satisfying $z \geq 0$, in the order version: $dz dx dy$.

Given $x^2 + y^2 + z^2 = 1$, and $z \geq 0$. Then, it yields that

$$0 \leq z \leq \sqrt{1 - x^2 - y^2}.$$

Moreover, by intersecting the given surfaces $z = 0$ and $x^2 + y^2 + z^2 = 1$ we obtain that $x^2 + y^2 = 1$. Thus, we obtain

$$-\sqrt{1 - y^2} \leq x \leq \sqrt{1 - y^2},$$

and

$$-1 \leq y \leq 1.$$

Hence, it follows that:

$$\iiint_E f(x, y, z) dV = \int_{-1}^1 \int_{-\sqrt{1-y^2}}^{\sqrt{1-y^2}} \int_0^{\sqrt{1-x^2-y^2}} f(x, y, z) dz dx dy.$$

Example 7.5. Evaluate the triple integral $\iiint_E z dV$, where E tetrahedron bounded by $x = 0$, $y = 0$, $z = 0$ and $x + y + z = 1$.

Observe that lower boundary of the tetrahedron is the plane $z = 0$, on the upper boundary is the plane $z = x - y - 1$. Therefore, it yields

$$\underbrace{0}_{\varphi_1(x,y)} \leq z \leq \underbrace{x - y - 1}_{\varphi_2(x,y)}.$$

Moreover, the intersection of the planes $z = 0$ and $z = 1 - x - y$, we obtain $x + y = 1$ in xy -plane, which creates the region D as follows:

$$D = \left\{ (x, y) \in \mathbb{R}^2 : 0 \leq x \leq 1, \underbrace{0}_{u_1(x)} \leq y \leq \underbrace{1-x}_{u_2(x)} \right\}.$$

Therefore, we get

$$\begin{aligned} \iiint_E z dV &= \int_0^1 \int_0^{1-x} \int_0^{1-x-y} z dz dy dx \\ &= \int_0^1 \int_0^{1-x} \frac{1}{2} z^2 \Big|_{z=0}^{z=1-x-y} dy dx \\ &= \int_0^1 \int_0^{1-x} \frac{(1-x-y)^2}{2} dy dx \\ &= \frac{1}{2} \int_0^1 \left[-\frac{1}{3}(1-x-y)^3 \right] \Big|_{y=0}^{y=1-x} dx \\ &= -\frac{1}{6} \int_0^1 -(1-x)^3 dx \\ &= \frac{1}{24} (1-x)^4 \\ &= \frac{1}{24}. \end{aligned}$$

Planar Transformations. A planar transformation T is a function that transforms a region G in one plane into a region R in another plane by a change of variables. Both G and R are subsets of R^2 . For example, Figure 6.3 shows a region G in the uv -plane transformed into a region R in the xy -plane by the change of variables $x = g(u, v)$ and $y = h(u, v)$, or sometimes we write $x = x(u, v)$ and $y = y(u, v)$. We will typically assume that each of these functions has continuous first partial derivatives, which means $\frac{\partial g}{\partial u}$, $\frac{\partial g}{\partial v}$, $\frac{\partial h}{\partial u}$ exist and are also continuous. The need for this requirement will become clear soon.

Definition 7.6 (One-to-One Transformation). *A transformation $T : G \rightarrow R$, defined as $T(u, v) = (x, y)$, is said to be a one-to-one transformation if no two points map to the same image point.*

Example 7.7. *Let T be defined by*

$$T(r, \theta) = (x, y), \quad \text{such that } x = r \cos \theta, y = r \sin \theta$$

Find the image of the polar rectangle

$$G := \left\{ (r, \theta) : 0 \leq r \leq 1, 0 \leq \theta \leq \frac{\pi}{2} \right\}$$

in the $r\theta$ -plane to a region R in the xy -plane. Show that T is a one-to-one transformation in G and find $T^{-1}(x, y)$.

Definition 7.8. *The Jacobian of the C^1 transformation $T(u, v) = (g(u, v), h(u, v))$ is denoted by $J(u, v)$ and is defined by*

$$J(u, v) = \left| \frac{\partial(x, y)}{\partial(u, v)} \right| = \begin{vmatrix} \frac{\partial x}{\partial u} & \frac{\partial x}{\partial v} \\ \frac{\partial y}{\partial u} & \frac{\partial y}{\partial v} \end{vmatrix}$$

Changing variables in triple integrals follows the same method as double integrals. Noticing that both cylindrical and spherical coordinate substitutions are examples of this method.

Suppose that G is a region in uvw -space and is mapped to D in xyz -space (see Fig. 6.9) by a one-to-one C^1 transformation $T(u, v, w) = (x, y, z)$, where $x = g(u, v, w)$, $y = h(u, v, w)$, and $z = k(u, v, w)$.

Therefore, any function $F(x, y, z)$ defined on D can be expressed as another function $H(u, v, w)$ defined on G as

$$F(x, y, z) = F(g(u, v, w), h(u, v, w), k(u, v, w)) = H(u, v, w)$$

Next, we state the following definition of Jacobian

Definition 7.9. *The Jacobian determinant $J(u, v, w)$ in three variables is given by*

$$J(u, v, w) = \begin{vmatrix} \frac{\partial x}{\partial u} & \frac{\partial x}{\partial v} & \frac{\partial x}{\partial w} \\ \frac{\partial y}{\partial u} & \frac{\partial y}{\partial v} & \frac{\partial y}{\partial w} \\ \frac{\partial z}{\partial u} & \frac{\partial z}{\partial v} & \frac{\partial z}{\partial w} \end{vmatrix}$$

Now, we are able to state the theorem that describes the change of variables for triple integrals.

Theorem 7.10. *Let $T(u, v, w) = (x, y, z)$, where $x = g(u, v, w)$, $y = h(u, v, w)$, and $z = k(u, v, w)$ be a one-to-one C^1 transformation, with a nonzero Jacobian, that maps the region G in the uvw -space into the region D in the xyz -space. If F is continuous on D , then*

$$\begin{aligned} \iiint_D f(x, y, z) dx dy dz &= \iiint_G f(g(u, v, w), h(u, v, w), k(u, v, w)) \left| \frac{\partial(x, y, z)}{\partial(u, v, w)} \right| du dv dw \\ &= \iiint_G H(u, v, w) |J(u, v, w)| du dv dw. \end{aligned}$$

Special Cases:

1. Cylindrical coordinate:

$$\begin{cases} x = r \cos \theta, \\ y = r \sin \theta, \\ z = z. \end{cases}$$

In this case, we have

$$J(r, \theta, z) = \begin{vmatrix} \frac{\partial x}{\partial r} & \frac{\partial x}{\partial \theta} & \frac{\partial x}{\partial z} \\ \frac{\partial y}{\partial r} & \frac{\partial y}{\partial \theta} & \frac{\partial y}{\partial z} \\ \frac{\partial z}{\partial r} & \frac{\partial z}{\partial \theta} & \frac{\partial z}{\partial z} \end{vmatrix} = \begin{vmatrix} \cos \theta & -r \sin \theta & 0 \\ \sin \theta & r \cos \theta & 0 \\ 0 & 0 & 1 \end{vmatrix} = r \cos^2 \theta + r \sin^2 \theta = r.$$

Therefore, we have

$$\iiint_D f(x, y, z) dx dy dz = \iiint_G f(r \cos \theta, r \sin \theta, z) r dr d\theta dz.$$

2. Spherical coordinates:

$$\begin{cases} x = r \sin \varphi \cos \theta, \\ y = r \sin \varphi \sin \theta, \\ z = r \cos \varphi. \end{cases}$$

In this case, we have

$$J(r, \varphi, \theta) = \begin{vmatrix} \frac{\partial x}{\partial r} & \frac{\partial x}{\partial \theta} & \frac{\partial x}{\partial \varphi} \\ \frac{\partial y}{\partial r} & \frac{\partial y}{\partial \theta} & \frac{\partial y}{\partial \varphi} \\ \frac{\partial z}{\partial r} & \frac{\partial z}{\partial \theta} & \frac{\partial z}{\partial \varphi} \end{vmatrix} = \begin{vmatrix} \sin \varphi \cos \theta & -r \sin \varphi \sin \theta & r \cos \varphi \cos \theta \\ \sin \varphi \sin \theta & r \sin \varphi \cos \theta & r \cos \varphi \sin \theta \\ \cos \varphi & 0 & -r \sin \varphi \end{vmatrix} = -r^2 \sin \varphi.$$

Thus, we can write

$$\iiint_D f(x, y, z) dx dy dz = \iiint_G f(r \sin \varphi \cos \theta, r \sin \varphi \sin \theta, r \cos \varphi) r \sin \varphi dr d\varphi d\theta.$$

Example 7.11. *Use cylindrical coordinate to calculate the triple integral of the function $f : \mathbb{R}^3 \rightarrow \mathbb{R}$ defined by*

$$f(x, y, z) = z^2 \sqrt{x^2 + y^2},$$

over the region $D := \{(x, y, z) \in \mathbb{R}^3 : x^2 + y^2 \leq 4, -1 \leq z \leq 3\}$.

By passing to the cylindrical coordinate, we can obtain

$$\begin{aligned}
 \iiint_{\mathcal{D}} f(x, y, z) dx dy dz &= \int_{-1}^3 \int_0^{2\pi} \int_0^2 z^2 \sqrt{r^2 \cos^2 \theta + r^2 \sin^2 \theta} r dr d\theta dz \\
 &= \int_{-1}^3 \int_0^{2\pi} \int_0^2 z^2 r^2 dr d\theta dz \\
 &= \left(\int_{-1}^3 z^2 dz \right) \left(\int_0^{2\pi} d\theta \right) \left(\int_0^2 r^2 dr \right) \\
 &= \frac{z^3}{3} \Big|_{-1}^3 \theta \Big|_0^{2\pi} \frac{r^3}{3} \Big|_0^2 = \frac{448\pi}{9}.
 \end{aligned}$$

8 Exercises:

Exercise 8.1. Evaluate the double integral

$$\int_0^4 \int_{\sqrt{x}}^2 \frac{x}{y^5 + 1} dy dx.$$

Solution. Notice that this integral can only be evaluated by reversing the order of integration as follows

$$\begin{aligned}
 \int_0^4 \left(\int_{\sqrt{x}}^2 \frac{x}{y^5 + 1} dy \right) dx &= \int_0^2 \left(\int_0^{y^2} \frac{x}{y^5 + 1} dx \right) dy \\
 &= \int_0^2 \frac{x^2}{2(y^5 + 1)} \Big|_{x=0}^{x=y^2} dy \\
 &= \int_0^2 \frac{y^4}{2(y^5 + 1)} dy \\
 &= \frac{1}{10} \ln(y^5 + 1) \Big|_{y=0}^{y=2} \\
 &= \frac{1}{10} \ln(33).
 \end{aligned}$$

Exercise 8.2. Consider the double integral

$$I = \int_0^2 \int_{x^2}^4 x e^{y^2} dy dx.$$

1. Sketch the region of integration \mathcal{D} .
2. Change the order of integration and evaluate the double integral I .

Solution. 1. The region of integration \mathcal{D} is presented as

$$\mathcal{D} = \{(x, y) \in \mathbb{R}^2 : 0 \leq x \leq 2, x^2 \leq y \leq 4\}.$$

It can be visualized as follows:

2. By changing the order of integration, we can write

$$I = \int_0^2 \left(\int_{x^2}^4 x e^{y^2} dy \right) dx = \int_0^4 \left(\int_0^{\sqrt{y}} x e^{y^2} dx \right) dy.$$

Therefore, we have

$$\begin{aligned} I &= \int_0^4 \left(\int_0^{\sqrt{y}} x e^{y^2} dx \right) dy \\ &= \int_0^4 \left[\frac{1}{2} x^2 y^2 \right]_{x=0}^{x=\sqrt{y}} dy \\ &= \int_0^4 \frac{1}{2} y^e y^2 dy \\ &= \frac{1}{4} e^{y^2} \Big|_{y=0}^{y=4} \\ &= \frac{e^{16} - 1}{4}. \end{aligned}$$

Exercise 8.3. Evaluate the double integral $\iint_D x dA$, where D is given by

$$D = \{(x, y) \in \mathbb{R}^2 : y \geq 0, x - y + 1 \geq 0, x + 2y - 4 \leq 0\}.$$

If $(x, y) \in D$, then we have $y \geq 0$, and $y - 1 \leq x \leq 4 - 2y$. The last inequality holds if $y - 1 \leq 4 - 2y$, which implies that y is between 0 and $\frac{5}{3}$. Therefore we get

$$\begin{aligned} \iint_D f(x, y) dA &= \int_0^{\frac{5}{3}} \int_{y-1}^{4-2y} x dx dy \\ &= \int_0^{\frac{5}{3}} \left[\frac{1}{2} x^2 \right]_{x=y-1}^{x=4-2y} dy \\ &= \frac{1}{2} \int_0^{\frac{5}{3}} [(4 - 2y)^2 - (y - 1)^2] dy \\ &= \frac{275}{54}. \end{aligned}$$

Exercise 8.4. Using the polar coordinate, evaluate the double $\iint_D (3x + y^2) dA$, where D is the region in the third quadrant between $x^2 + y^2 = 1$ and $x^2 + y^2 = 9$.

Solution. By passing to the change of variables : $x = r \cos \theta$ and $y = r \sin \theta$, we obtain

$$\iint_D (3x + y^2) dA(x, y) = \iint_{D'} [3r \cos \theta + r^2 \sin^2 \theta] r dA(r, \theta),$$

where

$$D' := \left\{ (x, y) \in \mathbb{R}^2 : 1 \leq r \leq 3, \pi \leq \theta \leq \frac{3\pi}{2} \right\}$$

Therefore, it yields

$$\begin{aligned} \iint_{D'} [3r \cos \theta + r^2 \sin^2 \theta] r dA(r, \theta) &= \int_{\pi}^{\frac{3\pi}{2}} \int_1^3 [3r^2 \cos \theta + r^3 \sin^2 \theta] dr d\theta \\ &= \int_{\pi}^{\frac{3\pi}{2}} \left[r^3 \cos \theta + \frac{1}{4} r^4 \sin^2 \theta \right] \Big|_{r=1}^{r=3} d\theta \\ &= \int_{\pi}^{\frac{3\pi}{2}} [26 \cos \theta + 20 \sin^2 \theta] d\theta \\ &= 26 \int_{\pi}^{\frac{3\pi}{2}} \cos \theta d\theta + 20 \int_{\pi}^{\frac{3\pi}{2}} \sin^2 \theta d\theta \xrightarrow{\frac{1}{2}(1 - \cos(2\theta))} \\ &= 26 \sin \theta \Big|_{\theta=\pi}^{\theta=\frac{3\pi}{2}} + [10\theta - 5 \sin(2\theta)] \Big|_{\theta=\pi}^{\theta=\frac{3\pi}{2}} \\ &= 5\pi - 26. \end{aligned}$$

Example 8.5. Compute the area between the curves: $(x - 2)^2 + y^2 = 4$ and $x^2 + y^2 = 4$.

Solution. The intersection of the curves $(x - 2)^2 + y^2 = 4$ and $x^2 + y^2 = 4$ gives $x = 1$ and $y = \pm\sqrt{3}$. Therefore, we obtain that

$$-\frac{\pi}{3} \leq \theta \leq \frac{\pi}{3}$$

Moreover, it follows from $\underbrace{r^2 \cos^2 \theta + r^2 \sin^2 \theta = 4}_{r^2=4}$ and $\underbrace{r^2 \cos^2 \theta - 4r \cos \theta + 4 + r^2 \sin^2 \theta = 4}_{r=4 \cos \theta}$ that

$$2 \leq r \leq 4 \cos \theta.$$

Thus, it yields

$$\begin{aligned} \text{Area} &= \int_{-\frac{\pi}{3}}^{\frac{\pi}{3}} \int_2^{4 \cos \theta} r dr d\theta \\ &= \int_{-\frac{\pi}{3}}^{\frac{\pi}{3}} \left[\frac{1}{2} r^2 \right]_{r=2}^{r=4 \cos \theta} d\theta \\ &= \int_{-\frac{\pi}{3}}^{\frac{\pi}{3}} [8 \cos^2 \theta - 2] d\theta, \quad \text{use: } \cos^2 \theta = \frac{1}{2}(1 + \cos(2\theta)), \\ &= \int_{-\frac{\pi}{3}}^{\frac{\pi}{3}} (2 + \cos(2\theta)) d\theta \\ &= [2\theta + \frac{1}{2} \sin(2\theta)] \Big|_{\theta=-\frac{\pi}{3}}^{\theta=\frac{\pi}{3}} \\ &= 2\sqrt{3} + \frac{4}{3}\pi. \end{aligned}$$

Exercise 8.6. Find: $\iint_D x^2 dA$, where

$$D = \{(x, y) \in \mathbb{R}^2 \mid x^2 + 4y^2 \leq 1\}.$$

Solution. For any $(x, y) \in D$, we have $x^2 + 4y^2 \leq 1$, which implies directly that

$$-\sqrt{1 - 4y^2} \leq x \leq \sqrt{1 - 4y^2}.$$

On the other hand, $\sqrt{1 - 4y^2}$ is well-defined if $1 - 4y^2 \geq 0$, and hence, it yields that $-\frac{1}{2} \leq y \leq \frac{1}{2}$.

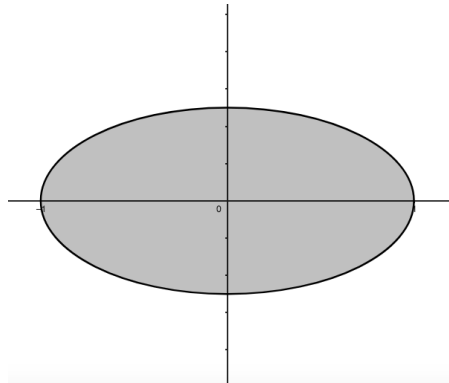

Figure 7.2: $D = \{(x, y) \in \mathbb{R}^2 \mid -\sqrt{1 - 4y^2} \leq x \leq \sqrt{1 - 4y^2}, -\frac{1}{2} \leq y \leq \frac{1}{2}\}$

Therefore, we have

$$\begin{aligned} \iint_D x^2 dA &= \int_{-\frac{1}{2}}^{\frac{1}{2}} \underbrace{\left[\int_{-\sqrt{1-4y^2}}^{\sqrt{1-4y^2}} x^2 dx \right]}_{\text{function of } y} dy \\ &= \int_{-\frac{1}{2}}^{\frac{1}{2}} \left[\frac{1}{3} x^3 \right]_{x=-\sqrt{1-4y^2}}^{x=\sqrt{1-4y^2}} dy \\ &= \frac{2}{3} \int_{-\frac{1}{2}}^{\frac{1}{2}} (1 - 4y^2)^{\frac{3}{2}} dy. \end{aligned}$$

To evaluate the last integral, we pass to the change of variable $y = \frac{\sin \theta}{2}$. Then, we get

$$\begin{aligned}
 \frac{2}{3} \int_{-\frac{1}{2}}^{\frac{1}{2}} (1 - 4y^2)^{\frac{3}{2}} dy &= \frac{1}{3} \int_{-\frac{\pi}{2}}^{\frac{\pi}{2}} \underbrace{(1 - \sin^2 \theta)^{\frac{3}{2}}}_{\cos^3 \theta} \cos \theta d\theta \\
 &= \frac{1}{3} \int_{-\frac{\pi}{2}}^{\frac{\pi}{2}} \cos^4 \theta d\theta \\
 &= \frac{1}{12} \int_{-\frac{\pi}{2}}^{\frac{\pi}{2}} (1 + \cos(2\theta))^2 d\theta \quad \text{use: } \cos^2 \theta = \frac{1}{2}(1 + \cos(2\theta)) \\
 &= \frac{1}{12} \int_{-\frac{\pi}{2}}^{\frac{\pi}{2}} (1 + 2 \cos(2\theta) + \cos^2(2\theta)) d\theta \\
 &= \frac{1}{12} \int_{-\frac{\pi}{2}}^{\frac{\pi}{2}} \left[1 + 2 \cos(2\theta) + \frac{1}{2}(1 + \cos(4\theta)) \right] d\theta \\
 &= \frac{1}{12} \int_{-\frac{\pi}{2}}^{\frac{\pi}{2}} \left[\frac{3}{2} + 2 \cos(2\theta) + \frac{1}{2} \cos(4\theta) \right] d\theta \\
 &= \frac{1}{12} \left[\frac{3}{2} \theta + \sin(2\theta) + \frac{1}{8} \sin(4\theta) \right] \Big|_{\theta=-\frac{\pi}{2}}^{\frac{\pi}{2}} \\
 &= \frac{\pi}{8}.
 \end{aligned}$$

Example 8.7. Evaluate the following double integrals:

(i) $\int_0^1 \int_0^{\sqrt{x}} \frac{2xy}{1-y^4} dy dx,$

(ii) $\int_0^1 \int_{x^2}^x x e^{-y^2} dy dx,$

(iii) $\int_0^1 \int_{\sqrt{x}}^1 \frac{x}{\sqrt{x^2+y^2}} dy dx.$

Exercise 8.8. Find the volume of the solid that lies under the paraboloid $z = x^2 + y^2$ and above the region D in the xy -plane bounded by the line $y = 2x$ and the parabola $y = x^2$.

From $(x, y) \in D$, we have $x^2 \leq y \leq 2x$, with $0 \leq x \leq 2$. Then, the region D can be visualized as follows:

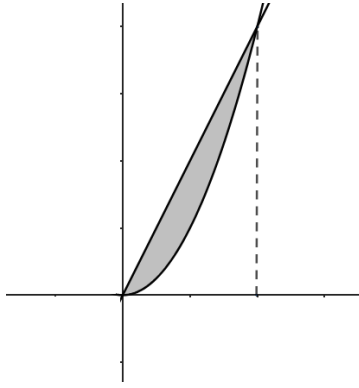

Figure 7.3: $D = \{(x, y) \in \mathbb{R}^2 : 0 \leq x \leq 2, x^2 \leq y \leq 2x\}$

Thus, the volume between the paraboloid $z = x^2 + y^2$ and the region D is given by

$$\begin{aligned}
 V &= \iint_D (x^2 + y^2) dA \\
 &= \int_0^2 \int_{x^2}^{2x} (x^2 + y^2) dy dx \\
 &= \int_0^2 \left[x^2 y + \frac{1}{3} y^3 \right] \Big|_{y=x^2}^{y=2x} dx \\
 &= \int_0^2 \left[-\frac{1}{3} x^6 - x^4 + \frac{14}{3} x^3 \right] dx \\
 &= \left[-\frac{1}{21} x^7 - \frac{1}{5} x^5 + \frac{7}{6} x^4 \right] \Big|_{x=0}^{x=2} \\
 &= \frac{216}{35}.
 \end{aligned}$$

We can get the same result if we consider the region of type *II* as follows:

$$D = \left\{ (x, y) \in \mathbb{R}^2 : 0 \leq y \leq 4, \frac{1}{2}y \leq x \leq \sqrt{y} \right\}.$$

Exercise 8.9. Use the triple integral to find the volume of the solid of the tetrahedron enclosed by $2x + y + z = 4$ and the coordinate planes.

Notice that the solid of the tetrahedron enclosed by $2x + y + z = 4$ and the coordinate planes is lies under the surface $2x + y + z = 4$ and above the region D given by

$$D = \{(x, y) \in \mathbb{R}^2 : 0 \leq x \leq 2, 0 \leq y \leq 4 - 2x\}.$$

Therefore, the volume is obtained by

$$\begin{aligned} V &= \int_0^2 \int_0^{4-2x} \int_0^{4-2x-y} dz dy dx \\ &= \int_0^2 \int_0^{4-2x} z \Big|_{z=0}^{z=4-2x-y} dy dx \\ &= \int_0^2 \int_0^{4-2x} (4-2x-y) dy dx \\ &= \int_0^2 \left[4y - 2xy - \frac{1}{2}y^2 \right] \Big|_{y=0}^{y=4-2x} dx \\ &= \frac{1}{2} \int_0^2 (4-2x)^2 dx \\ &= \left[8x - 4x^2 + \frac{2}{3}x^3 \right] \Big|_{x=0}^{x=2} \\ &= \frac{16}{3}. \end{aligned}$$

Exercice 01.

× Déterminer le domaine de définition de la fonction suivante

$$h(x, y) = \ln(2 - |x| - |y|).$$

Exercice 02.

Soit la fonction f définie par

$$f(x, y) = \begin{cases} \frac{x \ln(1 + x^3)}{y(x^2 + y^2)}, & (x, y) \neq (0, 0), \\ 0, & (x, y) = (0, 0). \end{cases}$$

× Montrer que h n'est pas continue au point $(0, 0)$.

Exercice 03.

Soit la fonction K définie par

$$K(x, y) = \begin{cases} \frac{x^2 + \sin(y^2)}{\sqrt{x^2 + y^2}}, & (x, y) \neq (0, 0), \\ 0, & (x, y) = (0, 0). \end{cases}$$

× Montrer que K est continue au point $(0, 0)$.

× K admet-elle des dérivées partielles au point $(0, 0)$?

× Est-elle différentiable au point $(0, 0)$?

Exercice 04.

Soit la fonction g définie par

$$g(x, y) = \begin{cases} xy \sin\left(\frac{1}{x^2 + y^2}\right), & (x, y) \neq (0, 0), \\ 0, & (x, y) = (0, 0). \end{cases}$$

× Étudier la différentiabilité de la fonction g au point $(0, 0)$.

Exercice 05.

Soit $f : \mathbb{R}^2 \rightarrow \mathbb{R}^3$ définie par $f(x, y) = (x^3y, 1, xe^{y^2})$, et soit $g : \mathbb{R}^3 \rightarrow \mathbb{R}$ définie par $g(u, v, v) = uvv$.

× Calculer les dérivées partielles de $z = g \circ f$.